

INTERNATIONAL ENERGY AGENCY
energy conservation in buildings and
community systems programme

Technical Note AIVC **35**

**Advanced Ventilation Systems
- State of the Art and Trends**

March 1992



***Air Infiltration and
Ventilation Centre***

University of Warwick Science Park
Barclays Venture Centre
Sir William Lyons Road
Coventry CV4 7EZ
Great Britain

This report is part of the work of the IEA Energy Conservation in Buildings & Community Systems Programme.

Publication prepared by
Annex V Air Infiltration and Ventilation Centre

Document AIC-TN-35-1992
ISBN 0 946075 56 5

Participating countries:

Annex V
Belgium, Canada, Denmark, Germany, Finland, France,
Italy, Netherlands, New Zealand, Norway, Sweden,
Switzerland, United Kingdom, and United States of
America

Distribution: Annex V only

Additional copies of this report may be obtained from:

The Air Infiltration and Ventilation Centre
University of Warwick Science Park
Barclays Venture Centre
Sir William Lyons Road
Coventry CV4 7EZ
Great Britain

Advanced Ventilation Systems - State of the Art and Trends

Bas Knoll

AIVC Visiting Scientist from
TNO Department of Indoor Environment
The Netherlands

© Copyright Oscar Faber PLC 1992

All property rights, including copyright are vested in the Operating Agent (Oscar Faber Consulting Engineers) on behalf of the International Energy Agency.

In particular, no part of this publication may be reproduced, stored in a retrieval system or transmitted in any form or by any means, electronic, mechanical, photocopying, recording or otherwise, without the prior written permission of the Operating Agent.

Preface

International Energy Agency

The International Energy Agency (IEA) was established in 1974 within the framework of the Organisation for Economic Co-operation and Development (OECD) to implement an International Energy Programme. A basic aim of the IEA is to foster co-operation among the twenty-one IEA Participating Countries to increase energy security through energy conservation, development of alternative energy sources and energy research development and demonstration (RD&D). This is achieved in part through a programme of collaborative RD&D consisting of forty-two Implementing Agreements, containing a total of over eighty separate energy RD&D projects. This publication forms one element of this programme.

Energy Conservation in Buildings and Community Systems

The IEA sponsors research and development in a number of areas related to energy. In one of these areas, energy conservation in buildings, the IEA is sponsoring various exercises to predict more accurately the energy use of buildings, including comparison of existing computer programs, building monitoring, comparison of calculation methods, as well as air quality and studies of occupancy. Seventeen countries have elected to participate in this area and have designated contracting parties to the Implementing Agreement covering collaborative research in this area. The designation by governments of a number of private organisations, as well as universities and government laboratories, as contracting parties, has provided a broader range of expertise to tackle the projects in the different technology areas than would have been the case if participation was restricted to governments. The importance of associating industry with government sponsored energy research and development is recognized in the IEA, and every effort is made to encourage this trend.

The Executive Committee

Overall control of the programme is maintained by an Executive Committee, which not only monitors existing projects but identifies new areas where collaborative effort may be beneficial. The Executive Committee ensures that all projects fit into a pre-determined strategy, without unnecessary overlap or duplication but with effective liaison and communication. The Executive Committee has initiated the following projects to date (completed projects are identified by *):

- I Load Energy Determination of Buildings*
- II Ekistics and Advanced Community Energy Systems*
- III Energy Conservation in Residential Buildings*
- IV Glasgow Commercial Building Monitoring*

- V Air Infiltration and Ventilation Centre
- VI Energy Systems and Design of Communities*
- VII Local Government Energy Planning*
- VIII Inhabitant Behaviour with Regard to Ventilation*
- IX Minimum Ventilation Rates*
- X Building HVAC Systems Simulation*
- XI Energy Auditing*
- XII Windows and Fenestration*
- XIII Energy Management in Hospitals*
- XIV Condensation*
- XV Energy Efficiency in Schools*
- XVI BEMS - 1: Energy Management Procedures
- XVII BEMS - 2: Evaluation and Emulation Techniques
- XVIII Demand Controlled Ventilating Systems
- XIX Low Slope Roof Systems
- XX Air Flow Patterns within Buildings
- XXI Thermal Modelling
- XXII Energy Efficient Communities
- XXIII Multizone Air Flow Modelling (COMIS)
- XXIV Heat Air and Moisture Transfer in Envelopes
- XXV Real Time HEVAC Simulation

Annex V Air Infiltration and Ventilation Centre

The IEA Executive Committee (Building and Community Systems) has highlighted areas where the level of knowledge is unsatisfactory and there was unanimous agreement that infiltration was the area about which least was known. An infiltration group was formed drawing experts from most progressive countries, their long term aim to encourage joint international research and increase the world pool of knowledge on infiltration and ventilation. Much valuable but sporadic and uncoordinated research was already taking place and after some initial groundwork the experts group recommended to their executive the formation of an Air Infiltration and Ventilation Centre. This recommendation was accepted and proposals for its establishment were invited internationally.

The aims of the Centre are the standardisation of techniques, the validation of models, the catalogue and transfer of information, and the encouragement of research. It is intended to be a review body for current world research, to ensure full dissemination of this research and based on a knowledge of work already done to give direction and firm basis for future research in the Participating Countries.

The Participants in this task are Belgium, Canada, Denmark, Germany, Finland, France, Italy, Netherlands, New Zealand, Norway, Sweden, Switzerland, United Kingdom and the United States of America.

CONTENTS

	Summary	1
1	Introduction	5
2	Ventilation needs	7
3	National Standards and Systems	9
	3.1 Review	
	3.2 Discussion	
4	Ventilation Systems - Common and Advanced Approaches	15
	4.1 Review	
	4.2 Classification of Common and Advanced Systems	
5	Discussion	21
	5.1 Local Intermittent Versus Continuous Background Ventilation	
	5.2 Separate Room Versus Central Dwelling Ventilation	
	5.3 Displacement Flow in Dwellings	
	5.4 Natural Versus Mechanical Ventilation	
	5.5 Heat Recovery or Alternative Energy Gain	
	5.6 Additional Ventilation	
6	Conclusions	29
7	Recommended Research and Development	31
8	References	33
	Appendix A Review of National Standards and Design Considerations	35
	Appendix B Review of Common and Advanced Ventilation Systems	49
	1 Air Movement Control Systems	
	1.1 Spot Flow Control Systems	
	1.2 Internal Roomflow Control Systems	
	1.3 Inter-rooms Flow Control Systems	
	1.4 Dwelling in or Outflow Control Systems	
	2 Flow Quantity Control Systems	
	2.1 Automatic Set-point Maintenance Systems	
	2.2 Automatic Setpoint Adjustment Systems	

3 Ventilation Heat Recovery Systems

4 Alternative Ventilation Energy Gain Systems

Appendix C Classification of Ventilation Systems

99

C1. Introduction

C2. Description of Ventilation Provisions

C3. Characterization of System Properties

Category 1: Efficient Application of Ventilation Air

1.1 Local applicability

1.2 Flowrate Adjustability

1.3 Air Flow Pattern

Category 2: Efficient Energy Use

2.1 Auxiliary energy need

2.2 Ventilation Heat Demand

Category 3: Costs

Category 4: Reliability

Category 5: Comfort

C4 Classification

SUMMARY

Increased health standards and the need to save energy in colder climates caused residential buildings to advance to the modern airtight and well-insulated dwellings we have today. In these dwellings ventilation has become a dominant factor, both from an indoor air quality and an energy conservation point of view.

This situation asks for consciousness on the part of applied ventilation systems. The report presents a review on present and advanced systems for basic ventilation and notes possible trends.

It focuses on residential ventilation systems for basic needs, regarding ventilation as a means of removing human generated pollutants to achieve acceptable indoor air quality.

It does not consider ventilation as a means of reducing the effects of highly avoidable pollutants, nor does this report consider special ventilation appliances or alternative techniques such as filtration or air cleaning.

Hence the report applies to dwellings where:

- building materials are used that have emissions already limited at the production stage;
- the floor is airtight and no extreme soil emittance of radon, methane or vapour appears;
- vapour barriers are applied to prevent vapour transport from the building shell;
- thermal bridges are avoided and reasonable insulation levels appear to prevent mould growth;
- no unvented combustion appliances are being used;
- additional ventilation means are applied to deal with incidental high internal heat loads, over occupancy, severe smoking and polluting household or hobby activities.

After a resumé of the demands for basic ventilation, a review is given of the major design considerations for residential ventilation systems in each country:

It considers the following topics:

- ventilation standards,
- ventilation system requirements,
- commonly applied ventilation systems,
- weathertype,
- building traditions,

- specific ventilation problems.

The standards review shows a reasonable level of agreement with regard to human-generated impurities, allowing the development of uniform ventilation systems for habitable rooms. On the other hand the standards show a large variation of flows for service rooms. Nevertheless, a general development of source-related local ventilation systems for service-rooms is considered to be possible.

The present ventilation systems of the different countries are developed from a natural ventilation tradition. The dominant factor in the development is considered to be the cost-effectiveness of energy conservation measures. In severe climates the review shows the general application of controllable mechanical exhaust systems in existing dwellings, while new houses are provided with mechanical supply and exhaust systems with heat-recovery. In moderate climates natural ventilation systems are still widely used, while mechanical exhaust systems are also applied on a significant scale. In mild climates natural ventilation is dominant. A general divergence of trends may be noticed. In moderate climates a further development of advanced natural ventilation systems may be seen, while in severe climates an improvement of mechanical systems is observed.

To get an extended view of possible future developments, advanced ventilation system approaches are reviewed.

The advanced systems are put into four categories, namely:

1. Air movement control systems, subdivided into spot, room, inter-room and dwelling in or outflow control systems;
2. Flow quantity control systems, subdivided into automatic setpoint maintenance and set-point adjustment systems;
3. Ventilation heat recovery systems;
4. Alternative ventilation energy gain systems.

A short description is given of each system and the main applications, properties and benefits are highlighted. The review shows a lot of system developments, which enable an increased energy conservation, while maintaining high indoor air quality standards, given by recent hygienic and health criteria. However, most advanced approaches focus on different ventilation aspects. Therefore, the common characteristics of advanced systems need a classification to enable a comparison to be made.

The classification is based on a questionnaire. The answers to this questionnaire may express each ventilation system's qualities on:

- efficient application of ventilation air, enabling minimum energy consumption at high indoor air quality levels,
- efficient energy-use,
- costs,
- reliability,
- comfort.

It is suggested that a rating system be developed based on this questionnaire. As a first approach some rough qualifications are given to a number of ventilation systems. This will enable a comparison of systems, resulting in some major points of concern, from which, after a discussion, the following research and developments are suggested:

- optimisation of local extraction systems;
- research on spatiotemporal ventilation;
- research on the applicability of displacement ventilation
- improvement of controlled natural ventilation;
- improvement of the efficiency of heat recovery devices and techniques;
- research on additional ventilation and its impact on energy consumption.

1

INTRODUCTION

In the early days men created buildings to provide shelter against wild animals and unfavourable weather conditions, such as rain, strong winds and high sunloads. With the use of fire this shelter expanded to some kind of indoor temperature control and led also to the first domestic energy use. With the invention of window glazing, the houses developed to more or less closed structures, and men became aware of the need for ventilation.

For centuries the chimney and openable windows provided this need, while cracks and gaps supplied permanent natural ventilation for major basic needs. Though this may suggest that ventilation was quite satisfactory and that indoor air problems did not occur, the opposite was true. Ventilation related indoor air problems are probably as old as housing itself. An old example of this is in the third book of the Bible, giving sanitary measures for houses with mould growth. The indoor air problems at that time were more related to the building techniques and materials than to the ventilation systems. Since that time building techniques and building quality advanced, (e.g., the use of cavity walls, crawlspaces, vapour barriers and sealings), firstly influenced by health improvement and, in the last decades, by energy conservation, man has become more aware of the importance of better controlled ventilation in residential buildings.

In colder climates it led to the present situation of well-insulated airtight construction of houses in which ventilation has developed from a less significant factor into a crucial one, from the energy conservation point of view. At the same time however, increasing health criteria may not be affected by energy conserving ventilation systems. This situation asks for consciousness of present ventilation systems, their future utility and possible new developments.

This report presents a review of advanced residential ventilation systems, design considerations and common and advanced approaches, focused on colder climates.

It begins with a resumé of ventilation needs in Chapter 2. In Chapter 3 it continues with a summary of official ventilation standards and system requirements on residential buildings of several more advanced countries, and a review of the most commonly used residential ventilation systems and the ventilation trends in these countries. In Chapter 4 a literature based review focuses on present ventilation systems (common and advanced approaches) which may be applied in dwellings, together with their benefits and restrictions. The majority of common and advanced systems are also classified in this chapter,

using an overall performance-index as an arbitrary rate. Chapter 5 discusses the new developments presenting, of course, the author's personal opinion. The objective of this discussion is to fulfill the function of a platform on which a more extended discussion about advanced ventilation systems can take place. Finally, after the conclusions in Chapter 6, recommendations for future research are dealt with in Chapter 7.

2

VENTILATION NEEDS

Ventilation is a means of extracting or diluting indoor air pollutants to levels. At certain levels these pollutants can represent a significant risk to occupant health, while at lower levels they merely cause varying levels of annoyance or reductions in occupant amenity. Build ups of pollutants can often cause structural damage, thus reducing pollutants to acceptable levels is of prime importance.

The IEA Annex IX work, summarized in AIVC Technical Note 26 [1], deals with occurring indoor air pollutants and their control strategy, and also suggests minimum ventilation rates. The basic needs for ventilation of dwellings, mentioned in this work, are:

- 8 dm³/s per person to avoid annoyance of human generated impurities.
- 0.5 to 1.0 air changes per hour in moderate climates to avoid condensation and mould growth caused by high levels of humidity, mainly produced by human activities, such as cooking, bathing, laundry drying, etc. Apart from ventilation demands, also building requirements have to be fulfilled, as mentioned in the Annex XIV work.

The basic ventilation provision fully provides for the oxygen needs of people and is sufficient to reduce carbon dioxide concentration.

Though the basic ventilation provision in principle should exclude the following impurities, in practice ventilation air may contain any number of them:

- tobacco smoke from mild smoking activities,
- human induced particulates and dust,
- organic substances emitted from the building,
- vapour, radon and methane emitted from the soil,
- combustion gases from small cooking and domestic hot water appliances.

In general this applies to dwellings where:

- building materials are used that have emissions already limited at the production stage,
- thermal bridges are avoided and reasonable insulation levels appear,
- the floor is airtight and no extreme soil emittance appears,
- a local kitchen exhaust hood is operating and effectively vented combustion appliances are being used.

Dwellings are supposed to have some kind of ventilation system to provide basic ventilation for most circumstances, without annoyance. Usually the ventilation flow is adjustable to changing incidental needs by a manual control system.

In general, dwellings also have openable windows to supply additional ventilation for special circumstances, such as:

- moderate to severe smoking,
- over occupancy (excessive human odour and heat production),
- high internal heat load situations (by solar radiation or heat producing apparatus),
- high vapour loads due to recent building activities,
- polluting household or hobby activities, (cleaning, painting, glueing, soldering, etc.),

Additional ventilation may be supplied too by other local ventilation devices in case of:

- combustion (supply of oxygen and exhaust of smells, gases, particulates and heat for extensive cooking, hot water boilers, heaters and open fireplaces),
- high vapour loads (caused by rainfall on hygroscopic, permeable walls or by wet crawlspaces),
- extreme soil emittance (radon or methane).

The current ventilation levels do not take into account the percentage of the population who are hypersensitive, such as those suffering from allergic bronchial reactions. Controlled relative humidities and low dust concentrations are of vital importance to them, and minimizing ventilation can directly affect their health. Therefore, an increase in the basic ventilation levels of dwellings, together with additional components to the ventilation system, such as filtration or dehumidification, would be helpful to this minority group.

3

NATIONAL STANDARDS AND SYSTEMS

3.1 Review

Advanced ventilation systems have to cope with current ventilation standards in various countries. New systems also have to adapt to existing buildings, installation and behavioural traditions. The aim of this chapter is to give a rough review of these limiting aspects.

The main sources utilized in this review are:

- AIVC Technical Note 30 concerning building airtightness and ventilation standards [2],
- papers from the AIVC's Bibliographic Database "AIRBASE".

In order to achieve a representative review, the following countries are represented:

Australia
Belgium
Canada
Denmark
Finland
France
Germany
Italy
Japan
The Netherlands
New Zealand
Norway
Sweden
Switzerland
United Kingdom
United States of America

In Appendix A each country's ventilation criteria are mentioned, together with ventilation system requirements. (For more detailed information see Technical Note 30 [2]).

The ventilation systems generally used are briefly described, and relative weathertype information, building traditions and specific ventilation problems are detailed.

3.2 Discussion

A comparison of different standards shows quite a wide variety. Overall ventilation varies from 0.4 ach to 1.5 ach. For habitable rooms ventilation demands can even go up to 3.0 ach. The actual flow variation, of course, depends on the common dimensions of dwellings and rooms in the different countries. With the basic need for ventilation depending on human generated impurities (Chapter 2), a comparison of flows per person would be more logical. The standards show a variation from 4.0 to 8.3 dm³/s per person for habitable rooms. The variation very much depends on the accepted indoor air quality limits per country. Detailed information of these limits is given in the work of Annex XVIII [3].

In general, standards require exhaust ventilation in service rooms such as the kitchen, bathroom and W.C.

The standards show a flow variation of:

- 10 to 50 dm³/s for the kitchen.
- 4.2 to 30 dm³/s for the bathroom, and
- 4.2 to 15 dm³/s for the W.C.

The basic indoor air criteria on which these flows are based are relative humidity and smells. The flows mainly rely on experiences with the different circumstances per country.

The differences per country depend upon:

- local weather and environmental conditions,
- building construction type (e.g., floor tightness, insulation and absorption properties),
- overall ventilation of dwellings,
- efficiency of local extraction provisions,
- local heating,
- inhabitants' behaviour,
- sanitary standards.
- national philosophies on ventilation.

Though the ventilation standards of the service rooms are very different, the pollutant sources show a great similarity. This allows service room systems to be generalized as local systems.

Some preliminary conclusions concerning ventilation standards in relation to ventilation systems may be:

- (i) The ventilation standards of different countries allow the development of uniform ventilation systems for habitable rooms, if some variation in accepted indoor air quality levels is taken into account;
- (ii) A general development of source related local exhaust ventilation systems for service rooms is considered to be possible.

Ventilation system requirements of different countries may distort these conclusions. However, since most of the requirements are not mandatory, but mainly for guidance, the conclusions will still stand.

Some other interesting items to discuss are:

What caused ventilation systems to emerge and why did they develop the way they did?

A comparison of building and ventilation systems shows all countries developing from a natural ventilation tradition. Some countries currently have hardly any standards or system requirements, and ventilation of their dwellings still relies on unintentional natural flows through an untight building envelope and simple fixtures such as wall vents and/or openable windows. The need for further development is often not that important, because of relatively few ventilation related problems and mild weather conditions which result in energy conservation measures being hardly, or not at all cost effective.

Other countries have cultivated their natural ventilation systems to prevent indoor air problems in energy conserving, more insulated and tighter houses. It has led to the use of provisions such as buoyancy dominated exhaust ducts and controllable air-inlets. In a particular case even some kind of passive indoor air quality control on the natural ventilation provisions is applied on a significant scale. This mainly applies to countries with a moderate climate.

Mechanical exhaust systems also are often used in moderate climates as well as in the majority of countries with severe climates. These systems are claimed to be less dependent on fluctuating weather conditions, thus giving a better control on the system ventilation and the unintentional crack flow.

In severe climates new airtight houses are being provided with mechanical supply and exhaust systems. An important reason is the applicability of heat recovery systems. Sweden is believed to have the most progressive standards from an energy conserving point of view, requiring heat recovery if the ventilation energy use exceeds a certain value. Also noticeable on this point is the use of indoor air quality standards by several countries, allowing an energy efficient operation by demand controlled ventilation systems.

Severe climatic summer conditions have also influenced ventilation system developments. Especially in North America, recirculating mechanical ventilation systems with air-cooling and heating are common.

Sometimes specific indoor air problems may interfere with a general ventilation trend. An example of this is severe radon emission of the soil, which does not allow depressurization of the house by a mechanical exhaust system. Such interference also relies on existing building techniques, in this particular case the use of underfloor spaces and the possibility of sealing them from the living space above.

In general, existing building traditions are believed to be of minor influence on ventilation trends, because countries with different building traditions but with comparable climatic conditions, more or less display parallel ventilation trends, though the types of ventilation systems may differ. On the other hand, it is suggested that changes in building techniques, especially energy conserving techniques such as insulation and airtightening, have their influence on ventilation trends.

Though countries may show similar general ventilation trends, e.g. advancing natural ventilation or applying mechanical exhaust, their ventilation systems and system components may differ greatly. These systems often are the result of different philosophies based on different combinations of design considerations.

The conclusions to be drawn from this discussion are:

(i) The development of ventilation systems is caused by an interaction of:

- climatic conditions,
- the need to conserve energy,
- the intention to maintain or even improve the indoor air quality,
- comfort,
- changing building techniques.
- ventilation philosophy.

(ii) The cost effectiveness of energy conservation measures is held to be a dominant factor in the past development of ventilation systems. In the present and future development also indoor air quality is expected to be of importance.

(iii) A general divergence may be noticed between the development of advanced natural ventilation systems in moderate climates and mechanical systems in severe climates.

The conclusions apply to the countries considered in this chapter and do not include a large group of energy consuming countries such as the Commonwealth

of Independent States and Eastern European countries. The reason for this is a lack of information.

From the little available information in AIRBASE, it is suggested that the majority of dwellings are naturally ventilated and that advanced ventilation systems are not common, however, high indoor air quality standards do exist within these countries. This means, therefore, that substantial additional information may be covered by this review. The fact that they are dealing with the same problems might be a good reason for improving cooperation.

4

VENTILATION SYSTEMS - COMMON AND ADVANCED APPROACHES

4.1 Review

The conclusions of Chapter 3 still do not answer a major question, that is: "What future developments of ventilation systems are to be expected?"

It is evident that the present situation is not a status quo. As in the past, much of the development will depend on energy prices. On the other hand there seems to be an awakening interest in indoor air quality. As usual much depends on the technical possibilities. For this reason advanced approaches in ventilation design will be reviewed in this Chapter.

The review of advanced ventilation systems is based on:

- papers from the AIVC's bibliographic database "AIRBASE", complete with the latest publications on IEA Annex XIV and XVIII;
- papers from the indoor environmental bibliographic database, "IBSEDEX";
- papers from world-wide patent literature database "DERWENT";
- some commercial product documentation;
- some other publications and reports.

The review shows quite a few approaches to energy conserving ventilation systems. They are put into four main categories, with the adjacent sub categories:

Category 1 Air Movement Control Systems

1.1 Spot flow control systems.

1.1.1 Local exhaust systems.

1.1.2 Jet Flow Systems.

1.1.3 Enforced local exhaust systems.

1.1.4 Localised ventilation systems.

1.2 Internal room flow control systems.

1.2.1 Mixing ventilation room systems.

1.2.2 Displacement ventilation system.

1.2.3 Forced vortex ventilation system.

1.3 Inter-room flow control systems.

1.3.1 Natural exhaust duct system with controlled supply.

1.3.2 Mechanical exhaust controlled supply systems.

- 1.3.3 Mechanical supply systems.
- 1.3.4 Balanced mechanical ventilation systems
- 1.3.5 Overflow ventilation systems.
- 1.4 Dwelling in-or outflow control systems.
 - 1.4.1 Radon or methane mitigation systems.
 - 1.4.2 Vapour mitigation systems.
 - 1.4.3 CombustionC ventilation systems.

Category 2 Flow Quantity Control Systems

- 2.1 Automatic set point maintenance systems.
 - 2.1.1 Temperature controlled natural supply.
 - 2.1.2 Pressure difference controlled natural supply.
 - 2.1.3 Pressure difference controlled mechanical ventilation.
- 2.2 Automatic set point adjustment systems.
 - 2.2.1 Presence dependant mechanical ventilation.
 - 2.2.2 Carbon dioxideC and odour controlled ventilation.
 - 2.2.4 Temperature controlled ventilation

Category 3 Ventilation Heat Recovery Systems

- 3.1 Air to air heat recovery
- 3.2 Air to heat pump systems.
- 3.3 Heat recovery air supply windows.
- 3.4 Dynamic wall heat recovery.

Category 4 Alternative Ventilation Energy Gain Systems

- 4.1 Soil-heated or-cooled ventilation air.
- 4.2 Solar heated ventilation air.

To these categories a fifth energy conserving category may be added, namely "Air Cleaning and Recirculation Systems". Although this is a realistic option for industrial application, at the present time it is not considered to be so for households. This has to do with the relatively low concentrations and types of pollution, which make aircleaning in dwellings very difficult and expensive, if not impossible. This does not exclude new developments to allow future applications. However the subject, since it does not concern ventilation systems but only ventilation related systems, is considered to be beyond the scope of this report, as are source reductive measures, and these are therefore, not discussed further.

The four remaining categories contain systems to be highlighted here. For each system the following properties are given:

- name
- objective
- description
- applications

- properties
- benefits
- references

4.2 Classification of Common and Advanced Systems

The review of Chapter 4 shows some interesting advanced approaches on ventilation systems or components. Each of them is focused on different ventilation aspects which have already been expressed by their division into different categories. An interesting question is:

"How do the different developments contribute to better ventilation, both from an energy and an indoor air quality point of view?"

To answer this question, the systems need to be classified in such a way that they can be compared both to each other and to an "ideal" ventilation system, having all their separate features. Such a classification does not only give an insight into the importance of implementing advanced approaches into the present ventilation systems of dwellings, but also might answer the question: **"What developments are still to be done"?**

A proper classification of ventilation systems preferably needs an objective and measurable rating system. One such rating system would be the cost-effectiveness of the systems. However, this rate is difficult to apply to developing systems, because the system costs might alter greatly during the different stages from development to implementation. Furthermore, this type of rating does not account for differences in indoor air quality.

Every rate being used for the classification of developing systems would be strongly predictive because of the lack of experimental data. Therefore, the development of a special rating system has been suggested. It has to give a classification of each ventilation system's main characteristics according to the five categories listed below:

1. Application of ventilation flows linking the location, the production and the flow pattern of pollutants;
2. Energy input or recovery;
3. Cost of installation and operation;
4. Reliability (durability and chance of disorders);
5. Effect on comfort.

If necessary the classification has to be differentiated to the type of outside climate. The primary thought behind the rating system is to give the potential ability of a ventilation system to use a minimum of energy for getting an acceptable indoor air quality, without annoyance.

Minimum ventilation rates form the best combination for ridding the indoor space of harmful pollutants and maintaining most energy efficiency (category 1). In the first place this needs the application of ventilation flows only on polluted locations, this will in turn reduce the "loss" of unused ventilation air in unpolluted areas. It will also restrict the dispersion of polluted air to large volumes of air, thus preventing the exchange of unnecessary large amounts of air and/or the exposure of unnecessarily large concentrations of pollutants. On the other hand, the optimum use of ventilation air may allow the supply of (partly) polluted air to locations with another type of pollution, when the combined effect of both pollutants is less than the sum of the pollution. It is also allowed when "used" ventilation air is supplied to a zone of direct local extraction of pollution. In this case, unacceptably high concentrations may occur in the exhaust air, but occupants would not be exposed to it.

Secondly, the ventilation flow rates have to be commensurate with the variable production rate of pollutants. The flowrates have to be independent of the variations of the outdoor climate, the operation of other control devices in the ventilation system and the occupants behaviour.

Thirdly, the flow pattern of the ventilation air has to provide an optimum coefficient of air change performance by distributing fresh air to the occupied zone and expelling polluted air from the occupied zone direct to the exhaust openings.

Apart from optimizing the use of ventilation air, minimum energy use may also be reached by minimizing the auxiliary energy need for transporting the air, and by the application of heat-recovery or alternative energy gain on the ventilation air (category 2).

Reducing the energy consumption is both an ecological and an economical matter. From the economical point of view the system costs are of importance. They are dealt with in the third category.

Advanced ventilation systems have a tendency to be complex. This may impair the systems' reliability and it proper use, thus leading to malfunctioning. Category 4 deals with these aspects.

In addition to this, the last category deals with the user-friendliness and the ability to provide well-conditioned supply-air, leading to a minimum fluctuation

of the inside conditions, (temperature, velocity, air quality), resulting in maximum comfort.

It must be noted that the rating system is based on the potential abilities of ventilation systems. In practice these potentials are often not reached for one or more of the following reasons:-

- simplifications
- design or installation faults,
- improper interaction between system components,
- the lack of commissioning,
- interference by the occupants, etc.

Though the ratings of Category 4 may give some indication of these points, much will depend on the good workmanship of the people involved. The classification, however, suggests an optimum use of the system's abilities.

A first approach for this classification system is presented in Appendix C.

Using the questionnaire of Appendix C, a rough, rather subjective classification has been carried out for a number of common and advanced ventilation systems.

The results are shown in Table 1 of Appendix C.

Comparing the ventilation systems using the qualifications of Table 1 of Appendix C, the next conclusions may be drawn:

- (i) Most ventilation systems do have a poor ability to direct ventilation air to polluted areas only.
- (ii) In addition to this, the application of decentralized flowrate-control is rare.
- (iii) In most systems no measures have been taken to improve the coefficient of air change performance.
- (iv) The advantage of mechanical ventilation systems is the applicability of heat recovery or alternative energy gain.
- (v) In general the system costs are increased by ventilation or energy-efficiency measures. Therefore the cost-effectiveness of these measures has to be considered.

(vi) The reliability of ventilation systems may be affected significantly by some types of advanced control.

(vii)The thermal conditions of decentralised supply systems need to be improved.

5

DISCUSSION

The purpose of discussing the aspects of ventilation systems, as highlighted in this report, is to recognise general trends on which extended research and development can be based.

The discussion does not account for ventilation as a means of reducing indoor air concentrations of impurities from building materials, the soil, etc., which may be avoided by careful building design. Nor does the discussion account for special ventilation appliances, e.g., on combustion apparatus.

5.1 Local Intermittent Versus Continuous Background Ventilation

The basic needs for ventilation are to avoid annoyance from human-generated impurities and to avoid condensation effects due to high vapour loads, mainly caused by household activities. Accepting the different indoor air quality limits per country, the basic need for controlling human-generated impurities seems to be less discussable than the fluctuating basic needs for humidity of the different countries. An interesting point to add to this discussion is the fact that the basic need of 0.5 to 1.0 ach for controlling humidity, mentioned in Chapter 2 (Annex IX result), commensurates with the basic need of 4 to 9 persons for controlling human-generated impurities, assuming a dwelling volume of 250 m³ and the highest indoor air quality standard concerning human-generated impurities. Though this ventilation need does not have to be fulfilled under all circumstances, the dominating level shows the importance of a well established ventilation need for humidity control.

Another important point is the fact that in well-constructed buildings the main vapour sources are very well located, contrary to the sources of humanly generated impurities. This allows an improved local extraction of vapour near the sources. It would mean a change from a low volume flow of continuous ventilation to a high volume intermittent flow. This change will lead to a reduction of the total ventilated air volume, thus saving energy. The intermittent ventilation also restricts the heat loss from the building mass, due to the limited heat diffusion of the structure. The maximum savings are restricted by vapour absorbance and draughts of the ventilation flow, especially in the bathroom. The vapour absorbance leads to a delayed emittance of vapour, so a certain amount of continuous ventilation will still be necessary. On the other hand vapour absorbance is very much dependent on the successful local extraction of vapour.

Furthermore, the restrictive use of hygroscopic building materials may be beneficial.

The occurrence of draughts depends on a proper distribution of ventilation air and the regular temperature of the air. The latter is dependent on the heating system used to heat the supply air. A successful local ventilation will put extra demands on the local controllability of the heating system. A (preferably automatic) source related control of local fan(s) or local terminal devices of a central ventilation system is suggested to apply the right flow rate to the right location. Examples of such a control, which have yet to be realised, are humidity-sensor control of a cooking hood or a bathroom exhaust. Apart from this local system a certain continuous overall ventilation for production of impurities by moving occupants is still necessary.

Therefore, the aim of a development of local vapour exhaust systems may be the reduction of the basic demand for continuous ventilation from the present range of 0.5 to 1.0 ach, to a range of 0.2 to 0.5 ach, matching the basic occupant needs.

As a consequence of this development, humidity would become a less dominant impurity in the control of basic ventilation. The preferred control of the basic ventilation system would be on carbon dioxide or human odours.

Another interesting subject of this development may be the combined use of the local ventilation system for other intermittent additional ventilation needs. A restriction for the development of local intermittent ventilation may be the increase of installation costs due to higher flow quantities, while the operation time of the system is reduced. An integration of the ventilation system in the building structure, for instance by using hollow cores in the walls for ducting, may be considered.

5.2 Separate Room Versus Central Dwelling Ventilation

An improved local control of vapour sources focuses the basic ventilation needs on human-generated impurities.

As occupants are moving freely within the dwelling, a central ventilation system for the whole dwelling seems to be the most practical solution. As a consequence a high air exchange between rooms is preferred, to apply or supply all ventilation air to occupied places and to avoid the waste of fresh air, of unoccupied places, by exhausting it without being used. This air exchange may easily be achieved by opening doors. However, when doors are closed the air exchange is considered to be insufficient. This situation may occur, for instance, in sleeping rooms during the night. Other disadvantages of air exchange via open doors are the lack of

privacy, the impossibility of creating different temperature zones, especially in the well-insulated house, and the unfavourable spread of odours and impurities.

By using acoustically dampened overflow provisions in internal walls or by using a mechanical recirculation-system, a few of these problems may be solved. However, the spread of impurities and the equalisation of indoor temperatures will still occur.

The spread of impurities may contradict local standards. The equalisation of indoor temperatures may reduce the thermal comfort and increase energy losses.

The solution to these problems would be to direct the main airflows to the major habitable rooms, with the supply of fresh air to the living room during the daytime, changing it to supply the bedrooms during the night. The best way to fulfil this purpose is the application of a local demand controlled ventilation system in each room or in dwelling zones instead of the central dwelling system. This system would be more reliable than a manually controlled one and also has the advantage of adjusting the ventilation flows to the actual number of occupants with their production of pollutants.

Furthermore, avoiding the local excess of an allowable concentration does not need a lowered set-point of the sensor system to deal with unpredictable differences in room concentrations, as with a central demand controlled ventilation system. This may lead to a decreased energy demand. The same goes for the ability of the system to react quickly on spatio temporal emissions of pollutants, which allows it to act more or less like a local exhaust system. Adjusting the ventilation flows to local demands would need local sensing and controllable vents in each room. Local sensing would need a sensor in each room or one sensor on a scanning-system to alternatively sense the concentration in each room or its exhaust duct.

Consequently the complexity and the total system costs would show a significant increase compared with a central controlled ventilation system, based on the present costs of the components. A future development of low-cost sensors and control systems however, may allow the application of demand controlled ventilation per room or alternatively per dwelling zone.

5.3 Displacement Flow in Dwellings

The application of displacement ventilation in dwellings is very rare, though in general the conditions in dwellings are not contradictory. However, the flow rates mentioned by most researchers, to operate the system properly are about 3 or 4 times the basic demands of dwellings. This means high recirculation flows have to be applied, turning the system into a so-called low velocity ventilation

system. The disadvantage is that the displacement flow will be impaired. However, ventilation efficiency may still be better than with complete mixing. For this reason the development of low velocity ventilation may be of interest for the application in dwellings.

5.4 Natural Versus Mechanical Ventilation

One of the conclusions of the review of ventilation standards and systems of different countries (Chapter 3) concerns the divergence of system developments between severe and moderate or mild climates.

In severe climates mechanical ventilation is preferred because of its ability to control flows better and to apply heat recovery.

In moderate and mild climates heat recovery is hardly cost-effective, consequently the simpler and cheaper natural ventilation systems or mechanical exhaust systems are still preferred.

The major disadvantage of the natural ventilation system is its dependence on the weather conditions. It makes both the ventilation flow directions and the flow rates difficult to control. The latest developments however, show that highly controllable natural ventilation is not impossible. When natural vents are properly dimensioned, basic ventilation rates can even be reached when natural forces are low. By automatically controlling the vents' opening areas the influence of changing weather conditions on flow rates may be compensated. By combining the system with stack-dominated vertical exhaust ducts, the flow directions may also be highly controllable. Apart from a proper dimensioning, the important factor in this system is the development of automatically controlled supply-vents.

An optimal functioning of these vents could be reached when the following features are added:

- the possibility of adjusting the control characteristic in order to compensate the infiltration flow.
- the possibility of operating on different flow rates, preferably automatically set by an indoor air quality sensing device.

A natural ventilation system with these features may provide ventilation rates for habitable rooms according to local demands of occupants, without energy consuming overshoot due to uncontrollable infiltration flows. In moderate climates the system is also capable of providing unheated supply airflows up to basic demands, without causing draughts.

The disadvantage of the system is the natural exhaust, where large exhaust ducts are necessary to control ventilation flow directions. Still the exhaust flows are expected to be too small to allow high intermittent flows for effective local exhaust.

A compromise may be to use an auxiliary fan to:

- provide high intermittent local exhaust flows,
- reduce the dimensions of exhaust ducts,
- ensure correct flow directions under unfavourable conditions,
- allow the application of heat pump heat recovery.

For a proper functioning of the local exhaust system also, a control on terminal exhaust devices and an adjustment of the local supply is preferable (see Chapter 5.1).

In this set-up the basic needs are still provided with a natural ventilation system, while an auxiliary mechanical exhaust system is operated intermittently for local extraction of vapour. The main question of this set-up concerns the cost effectiveness of the auxiliary system.

The application of an auxiliary mechanical system will close the gap between natural and mechanical ventilation systems.

This can make people decide to apply a mechanical exhaust system as well for basic ventilation.

Two points of concern from this choice are:

- (i) the system still needs proper supply provisions to the right locations,
- (ii) the demands for a basic ventilation system are different from the demands for a local exhaust system.

The supply in mechanical exhaust systems is very much dependent on the distribution of the air leakage of the building. This may lead to highly under ventilated rooms, while the mean ventilation of the dwellings is sufficient. Therefore, this system requires a certain level of airtightness of the structure in order to work efficiently. Also, controllable supply-provisions are preferred to prevent over ventilation at higher wind velocities. The demands on this type of supply provision are very similar to the demands on the natural supply provisions. Therefore, a combined development is suggested.

The second remark on the mechanical exhaust system concerns the differences between continuous and temporary flow rates. Present standards already show a ratio of 1 to 4. For a proper local extract even higher ratios are expected, and this

is hard to fulfil efficiently with one system. It means that the mechanical exhaust system may also end up with auxiliary provisions for mechanical local extraction, the same as the natural ventilation system. This also accounts for mechanical supply and exhaust systems. The advantage of this system is the possibility of distributing ventilation air efficiently and to apply air-to-air heat recovery. On the other hand, this system puts the highest demands on the airtightness of the building to reduce infiltration energy losses. Furthermore, the present systems barely allow variations of flows to separate rooms to adjust the ventilation to local needs. This modification would need adjustable terminal devices, automatically compensating pressure fluctuations in the system, which occur by the fan control and the adjustment of other terminal devices. The preferred adjustment of the terminal devices would be local demand controllers.

5.5 Heat Recovery or Alternative Energy Gain

The application of air-to-air heat recovery or air-to-heat pump systems is profitable in severe climates. However, further improvement in the efficiency of these devices could promote their use in moderate climates. An advantage of several types is the ability to control humidity up to a certain level. Their vapour rejection at low temperatures may specifically be beneficial in severe climates to prevent low relative humidities, whilst dehumidification at higher temperatures still occurs.

From the other types of heat-recovery, the dynamic wall may deserve more attention. The dynamic wall application needs no unrealistic changes of building techniques, while it uses common building materials.

Its advantages are:

- restriction of the insulation level,
- preheating of ventilation air up to 80% of the outside- inside temperature difference,
- improved distribution of ventilation air within the building shell, reducing cross-ventilation and increasing the controllability of ventilation.

The disadvantage of the system is that ventilation air pathways are hardly accessible for cleaning and inspection. Furthermore, the system's contribution to total heat-recovery is small because heat loss through insulated parts is small compared to windows and ventilation. Also, large surface areas of dynamic wall are needed for relatively small airflows. Therefore, the development of this system will focus on a building integrated design that does not need servicing.

The alternative energy gain systems show hardly any perspectives at present. Future developments of, for instance, solar collector systems may change this.

However, the present work in this field does not particularly indicate the use of solar applications on ventilation air.

5.6 Additional Ventilation

The present developments of ventilation systems merely apply to the basic ventilation systems. Yet results of on-site tests generally show ventilation levels, significantly exceeding basic levels, due to the occupants behaviour. This might indicate a large need for additional ventilation. As a consequence the ventilation energy consumption may be very much dependent on the level and efficiency of additional ventilation. Little is known about this field. Tests on the relation of ventilation and occupants' behaviour show a manual control on human sensor signals like visible condensation, hot/cold, draughts and odours. Apart from sensing odours the human sensing system is not a very accurate one. Hence over or under ventilation and large hysteresis effects occur.

The tests also show a reducing of additional ventilation with decreasing outside temperatures. Cold and draught sensations are responsible for this. Its advantage may be a restriction of the energy consumption by additional ventilation. However, the indoor air quality may be impaired by this effect.

Research on the importance, the needs and the mechanisms of additional ventilation are recommended. This research may lead to the development of improved additional ventilation systems.

6

CONCLUSIONS

***Different national ventilation standards show a variety of habitable ventilation demands of u.o to 8.3 dm³/s per person. The variation mainly depends on differences in accepted indoor air quality levels.**

***Different national ventilation standards show a variation of service rooms ventilation of:**

- 10 to 50 dm³/s for kitchens
- 4.2 to 30 dm³/s for bathrooms
- 4.2 to 15 dm³/s for wc's

The variable demands mainly rely on local experiences with the different circumstances per country. Nevertheless, the different ventilation demands are based on very similar pollutant sources.

***The primary reasons for the development of the present ventilation systems are:**

- the climatic conditions
- the need to conserve energy
- the intention to optimise indoor air quality
- the presence of specific pollutant sources
- improving building techniques
- ventilation philosophy

*** A general trend to be noticed is the development from natural ventilation systems into mechanical exhaust systems in moderate climates or into mechanical supply and exhaust systems in severe climates.**

At the same time, there appears to be an awakening interest in advanced natural ventilation systems, especially in moderate climates. In mild climates natural ventilation systems are still widely used and hardly any trend appears.

*** In general, present residential ventilation systems show poor relations between the ventilation flows and the production rates, periods and locations of pollutant sources.**

Even in modern, demand controlled ventilation systems an improvement on these relations is considered to be possible.

Hence, ventilation air may be applied more efficiently, leading to energy savings and improvements of indoor air quality.

* The similarity of habitable ventilation standards allows a closer international cooperation in the development of habitable ventilation systems, especially between countries with commensurating climates. This needs agreement on an international ventilation philosophy.

* As a second field of international cooperation the development of source related local exhaust ventilation systems for service rooms is suggested.

7

RECOMMENDED RESEARCH AND DEVELOPMENT

The trends in ventilation systems noticed in this report focus on some new fields that require the following extended research and development.

7.1 Optimisation of Local Extraction Systems for Main Sources, Such as Cooking and Bathing, Concerning:

- optimum hood design (shape and location),
- optimum exhaust flow rate,
- minimum vapour absorbance of the room,
- minimum energy consumption,
- draught free supply provisions,
- additional heating demands,
- demand control (e.g. humidity control).

Also the use of these provisions for general additional ventilation may be investigated.

7.2 Research on the Effects of Spatiotemporal Controlled Ventilation (Supply and Exhaust Directed to Occupied Rooms Only):

- energy conservation potential,
- effect of occupants behaviour (movement, opening doors),
- consequences on the ventilation system (local supply and exhaust provisions),
- automatic control systems (locations scanning sensor system, adjustment of ventilation terminal devices and fans).

7.3 Research into the Applicability of Displacement or Low-velocity Ventilation in Dwellings:

- energy conservation,
- effects of occupants' behaviour,
- effects on the indoor air quality, especially from particular sources like tobacco smoke,
- consequences of the choice of the ventilation system, the shape and location of ventilation terminal devices, etc.

7.4 Improvement of Both Flow Direction and Flow Rate Control in Natural Supply Systems by:

- development of self-regulating, draught-free supply vents with demand-control and compensation of infiltration flows,
- optimisation of natural or mechanical exhaust provisions.

7.5 Research on and Development of Building Integrated Dynamic Insulation.

7.6 Improvement of the Energy Efficiency of Heat Recovery Devices.

7.7 Research on the Need for Additional Ventilation, with its Impact on Energy Consumption Depending on the Occupants Behaviour.

8

REFERENCES

- (1) Trepte L and F Haberda
IEA Annex 9. Minimum ventilation rates and measures for controlling indoor air quality.
AIVC Technical Note 26, October 1989.
- (2) Colthorpe K A
Review of Building Airtightness and Ventilation Standards.
AIVC Technical Note 30, September, 1990.
- (3) Raatschen W
IEA Annex 18. Demand Controlled Ventilating System. State of the Art Review.
Swedish Council for Building Research, Stockholm, February 1990

APPENDIX A: REVIEW OF NATIONAL STANDARDS AND DESIGN CONSIDERATIONS

Australia

Ventilation Standard:

-

System Requirements:

Fixed ventilation in "wet areas". Until recently, fixed ventilation in all habitable rooms.

Common Systems:

Ceiling vents in laundry, bathroom and kitchen. One or more fixed wall vents of about 0.01m² per habitable room.

Weather type:

Mild climate in the majority of populated areas, mainly on the East Coast. Mean wind velocity = 3.4 m/s.

Common Dwellings:

Detached, single-storey timber framed with plasterboard inside and brickwork outside. Concrete slab-on-ground or suspended timber floor. Mean air leakage 26 ach at 50 Pa, of which 40% by fixed wall vents.

Ventilation Problems:

Radon problems in earth-wall and dugout dwellings.

Belgium

Ventilation Standard:

In preparation. (NBN D50-001)

System Requirements:

Fresh air supply to bedrooms; design value 1m³/s per m² floor area.

Fresh air supply or overflow of bedroom air to living room.

Exhaust in service rooms.

Common Systems:

Openable windows.

The use of small ventilation devices, ventilation ducts or mechanical ventilation is still rare.

Weathertype:

Moderate. Temperatures down to about -8 °C.
Average heating season temperature 5 to 8 ° C.
Mean wind velocity 4.0 m/s.

Common Dwellings:

Low-rise, detached as well as rows. Brickwork.
Mean leakage 10 ach at 50 Pa.

Ventilation Problems:

Condensation, odours and radon.

Canada

Ventilation Standard:

Natural ventilation opening areas:

- kitchen and habitable rooms 0.28m²
- bathroom and WC 0.09m²

Mechanical ventilation up to 1.0 ach.

System Requirements:

Preliminary requirements for the installation of mechanical ventilation systems are given.

Main highlights are:

- minimum airflow 5 dm³/s to habitable rooms,
- and 10 dm³/s to basement and master bedroom.
- additional ventilation of 25 dm³/s.
- local extract 30 dm³/s in kitchens,
- and 10 dm³/s in bathrooms.

Common Systems:

In old houses (roughly before 1945) natural ventilation through cracks and vents in the building envelope. Mechanical exhausts with supply through cracks or balanced ventilation in newer houses.

Weathertype:

Severe climate, with temperatures down to about -35 °C in populated areas.

Common Dwellings:

Detached bungalow or two-storey with basement. High-rise apartment buildings in suburban areas.

Mean air leakage:

- 10 ach at 50 Pa, before 1945.
- 5 ach at 50 Pa, between 1945-1960.
- 4 ach at 50 Pa, between 1960-1980.
- 2 ach at 50 Pa, recent airtight houses.

Ventilation Problems:

Radon, condensation, formaldehyde and combustion gases (backdraughting of fuel burning appliances).

Denmark

Ventilation Standard:

During at least 75% of the heating season a minimum air change rate of 0.5ach.

Kitchen 15-20 dm³/s(mech.) or 1.5-2dm² (nat.).

Bathroom/WC 15dm³/s(mech.) or 1.5dm²(nat).

System Requirements:

The combination of (ducted) ceiling ventilators and wall-vents must assure the ventilation demand. The distribution of wall-vents must assure sufficient supply airflows to all rooms.

Common System:

Natural ventilation through about two vertical ducts and at least four wall-vents for low-rise buildings. Mechanical exhaust or exhaust and supply for high-rise buildings.

Weathertype:

Moderate climate. Temperature during 97% of the time over -6 °C. Mean wind velocity 4.6 m/s.

Common Dwellings:

1 or 2-storey housing units to high-rise apartment blocks.

Mainly brickwork.

Most airtight houses 3 ach at 50 Pa, which leads to an estimated mean air leakage of roughly 12 ach at 50 Pa.

Ventilation Problems:

-

Finland

Ventilation Standard:

Regulations give binding values for indoor air concentrations. Ventilation rates are given as design guidance, but in practice almost always applied. They are:

- bedrooms 4 dm³/s.person or 0.7 dm³/s/m² floor area.

- living rooms 0.5 dm³/s.m² floor area.

- kitchen exhaust flow 20 dm³/s.

- bathroom exhaust flow 15 dm³/s

- toilet exhaust flow 10 dm³/s

The exhaust flows may be reduced if the rooms are not in use, provided the whole dwelling ventilation is above 0.4 ach.

System Requirements:

There are rules to get a type approval for components such as fresh air intake devices, supply and exhaust devices, ducts, filters and heat recovery equipment. Regulations are given to restrict noise from mechanical ventilation systems. Some guidance is given on means to control humidity and on the control system of both mechanical and natural ventilation to take into account energy savings. Furthermore, guidance is given on aspects of air distribution, air pressures, outdoor air intake and exhaust with mutual distance. Leakage of the mechanical ventilation system is limited to 6% of the total flow rate. Finally, regulations also apply to the documentation, testing, maintenance, safety and user instructions of ventilation systems.

Common Systems:

Mechanical exhaust systems became common during the last decades (e.g. 60% of the present apartment buildings). Older buildings have natural ventilation.

Weathertype:

Severe climate. Temperatures down to about -30 °C.

Common Dwellings:

Both high-rise and low-rise buildings presently with a concrete construction and low air leakage values (indication about 3 ach at 50 Pa).

Ventilation Problems:

Condensation, stuffiness, spreading of odours between flats and draught.

France

Ventilation Standard:

Exhaust flows, depending on number of habitable rooms (number in brackets):

- kitchen 21(1), 25(2), 29(3), 34(4) or 38 dm³/s (5),
- first bathroom 4.2 dm³/s () or 8.4 dm³/s(3),
- first W.C. 4.2 dm³/s () or 8.4 dm³/s(4),
- every second bathroom or W.C. 4.2 dm³/s. Supply through all habitable rooms.

System Requirements:

Air supply in all habitable rooms through special devices directly from the outside. Exhaust from service rooms through vertical ducts. If the kitchen has mechanical extract in collective buildings, all service rooms must have mechanical extract. Modulation of airflows according to temporary needs is allowed.

Common systems:

90% of flats and 70% of individual dwellings have a mechanical exhaust system. Humidity-controlled systems have now become of some significance.

Weathertype:

Mild climate, except for Alpine regions.

Common Dwellings:

Both high-rise and low-rise buildings, mainly with a brick or concrete construction.

Ventilation Problems:

Radon, draught from inlets, incorrect operation of vents because of fouling.

Germany

Ventilation Standard:

Habitable rooms 1.0 to 1.5 ach (based on 5.5 to 8.3 dm³/s.person) Bathrooms and toilets 6 ach.

Exhaust flows:

- kitchen 33 dm³/s
- internal bathroom 16.7 dm³/s
- internal toilet 8.3 dm³/s

System Requirements:

-

Common Systems:

Mainly natural ventilation via openable windows of the turn/chuck type. In new houses also small wall-vents. In old flats exhaust ducts of the shunt type (not allowed anymore).

Weathertype:

Moderate to severe climate. Average temperature during heating season -2 °C.

Common Dwellings:

Detached low-rise buildings. In suburban areas also high-rise buildings. Mainly brick or concrete construction. High airtightness of windows. No airtightness values of dwellings available.

Ventilation Problems:

Draughts from inlets.

Italy

Ventilation Standard:

Habitable rooms 4.2 dm³/s.person. or 0.42 dm³/s.m² floor area.

Kitchen 1 ach

Bathroom 2 ach

Ante-bathroom 1 ach

Entrance halls 2.8 dm³/s times the number of accessible rooms.

System Requirements:

Size and type of natural vents can be calculated using provided equations.

Openable window area of habitable rooms and the kitchen at least 1/8th of the

floor area.

Bathrooms must be provided with an external opening or mechanical ventilation. Where natural ventilation is unlikely to be satisfactory, mechanical ventilation should be provided in kitchens, bathroom, etc.

Common Systems:

Natural ventilation.

Weathertype:

Mild climate to moderate in northern regions. Average temperature during the heating season approximately 10 to 5 °C.

Common Dwellings:

High-rise buildings and detached low-rise buildings. Brick and concrete construction.

Ventilation Problems:

-

Japan

Ventilation Standard:

5.5 dm³/s.person.

Exhaust for combustion apparatus:

- flue-less 40 x theoretical combustion production.
- with hood 20 x theoretical combustion production.
- exhaust duct 2 x theoretical combustion production.

System Requirements:

-

Common Systems:

Natural ventilation via cracks, openable windows and supply ducts. Presently extended with local exhaust fans in service rooms.

Weathertype:

-

Common Dwellings:

Conventional detached timber framed wooden houses. In suburban areas high-rise apartment buildings of steel reinforced concrete.

Mean air leakage value approximately 13 ach at 50 Pa.

Ventilation Problems:

Radon and combustion gases of open fire local heaters and kitchen appliances.

The Netherlands

Ventilation Standard:

7.0 dm³/s.person: restricted total for living room between 21 and 42 dm³/s.

Design value for bedrooms 1 dm³/s.m² floor area.

Exhaust flows:

- kitchen 21 - 28 dm³/s
- bathroom 14 dm³/s
- W.C. 7 dm³/s

System Requirements:

Exhaust by vertical ducts to the roof. Supply by wall or window vents in habitable rooms, situated at least 1.8 m. above floor level, adjustable to temporary demands. Fresh air intake of bedrooms may be used as supply air to the living room and from there to the exhausts. Buildings higher than 13m require mechanical ventilation. The design value for natural ventilation openings is 1m³/s per m² opening area.

Common Systems:

Natural ventilation by small window vents or grilles in combination with vertical ducts. In buildings above 13m high and in new dwellings mechanical exhaust.

Weather type:

Moderate climate with temperatures down to -12 °C and an average of 5 °C for the heating season. Average wind velocity 5 m/s.

Common Dwellings:

Rows of two-storey buildings. In suburban areas also high-rise apartment buildings. Mean air leakage value 9 ach at 50 Pa.

Ventilation Problems:

Condensation, draught from inlets and possible backdraught in ducts.

New Zealand

Ventilation Standard:

-

System Requirements:

Minimum area of openable windows 5% of floor area in each room.

Common Systems:

-

Weather type:

Mild climate in populated areas.

Common Dwellings:

No information about dwellings types. Mean air leakage 10 ach at 50 Pa.

Ventilation Problems:
Condensation problems.

Norway

Ventilation Standard:

-

System Requirements:

Habitable rooms and the kitchen must have openable windows or wallvents of 30cm² each room.

The bathroom must have an opening above or below the door of 100 cm².

Exhausts (mechanical resp.natural):

- kitchen 22 dm³/s or 200 cm² duct.
- bathroom 17 dm³/s or 150 cm² duct.

Common Systems:

Natural supply through wall vents in habitable rooms. Natural or mechanical exhaust ducts in service rooms.

Weathertype:

Severe climate. Average temperature during the heating season -2 to -8 °C.

Common Dwellings:

Conventional low-rise wooden houses. High-rise apartment buildings.

Mean air leakage values respectively 5 and 1 ach at 50 Pa.

Ventilation Problems:

Draught from inlets. Incorrect operation because of fouling.

Sweden

Ventilation Standard:

0.35 dm³/s.m² of floor area for the whole dwelling.

Bedrooms 4.0 dm³/s for each sleeping place.

Kitchen 10.0 dm³/s.

Service rooms like bathroom, toilet, laundry room, etc. 10.0 dm³/s each, increased with 1.0 dm³/s for each m² floor area exceeding 5m².

Bathrooms without an openable window 30 or 15 dm³/s.

System Requirements:

The kitchen must have a local mechanical ventilation system that captures at least 75% of the cooking gases. Bathrooms without an openable window must have mechanical ventilation. Temporary occupied rooms should have an air exchange rate which prevents health risks or building damage. Heat recovery is required for ventilation systems with energy demands exceeding 2 MWh/year. Heat exchangers in a heat recovery system must have a 60% thermal efficiency. A

heat pump should at least give the same energy reduction or the energy demand for domestic hot water.

Common Systems:

The traditional systems have wall-inlets and natural or mechanical ventilated exhaust ducts. The common system in new homes and multi-storey buildings is mechanical supply and exhaust often with air heating and recirculation of air.

Weathertype:

Severe climate with temperatures down to -30 °C.

Common Dwellings:

Both low-rise and high-rise buildings. Conventional buildings of wood. Modern buildings of concrete.

Main air leakage:

- 12 ach at 50 Pa, before 1920
- 8 ach at 50 Pa, between 1921-1940
- 6 ach at 50 Pa, between 1941-1960
- 5 ach at 50 Pa, between 1961-1975
- 4 ach at 50 Pa, after 1976

Ventilation Problems:

Condensation in or on the building envelope.
Radon.

Switzerland

Ventilation Standard:

There are no federal standards for dwellings, although local authorities may have their own standards.

German standards are often used for guidance.

System Requirements:

In buildings with an airtightness below defined values and with window ventilation, provisions are required to guarantee the necessary basic ventilation. In buildings with exhaust ventilation appropriate inlet openings are required to ventilate all necessary zones.

Common Systems:

Naturally ventilation, often with additional mechanical fans in service rooms. In older houses natural ventilated ducts are also used.

Weathertype:

Moderate climate to severe climate in Alpine regions. Wind exposure very dependent on location.

Common Dwellings:

Wood constructions in Alpine regions, often with concrete basement. Concrete or brick constructions in suburban areas.

Ventilation Problems:

Some condensation problems.

Combustion gases from heating appliances.

United Kingdom

Ventilation Standard:

1 ach in habitable rooms and 3 ach in service rooms (mechanical ventilation) or each room an opening area for natural ventilation of 5% of the floor area, plus a 40cm² controllable vent.

Deviating Scottish standards are:

- 3ach in habitable rooms and the W.C., or opening area 1/30th of the floor area plus 40cm² trickle ventilators in the habitable rooms and kitchen,
- 64 dm³/s mechanical extract in the kitchen,
- 28 dm³/s mechanical extract in the bathroom.

System Requirements:

Some part of ventilation openings must be at least 1.75m above floor level.

Bathroom ventilation may be intermittent but should run for at least 15 minutes after the use of the room stops.

The 40cm² vents for background ventilation should be controllable and secure and located so as to avoid undue draughts.

The Scottish standard requires an ability for fans of habitable rooms and kitchens to continuously operate at low speed.

Other UK requirements apply to roof ventilation to prevent condensation and to ventilation for combustion apparatus.

Common Systems:

Natural ventilation through openable windows. In kitchens exhaust ducts may be applied.

Weather type:

Moderate climate in the main populated area.

Common Dwellings:

Detached low-rise brick buildings. High-rise apartments and rows of houses in suburban areas.

Mean air leakage value 14 ach at 50 Pa.

Ventilation Problems:

Condensation. Draughts from air inlets.

United States of America

Ventilation Standard:

Habitable rooms 7.5 dm³/s per person. Kitchen 50 dm³/s intermittent or 12 dm³/s continuous. Bathroom and W.C. 25 dm³/s intermittent or 10 dm³/s continuous.

An alternative approach is provided using restricting indoor air concentrations of all known contaminants of concern.

System Requirements:

The first bedroom is supposed to be occupied by at least 2 persons and additional bedrooms by 1 person.

Common Systems:

Natural ventilation through openable windows and stacks of wood burning appliances, assisted by intermittently operating local exhaust fans in service rooms. Mechanical exhaust and balanced systems in new houses and high-rise buildings.

Weather type:

Mild to severe climate in the main populated areas. Average temperature during the heating season 10 °C to -5 °C. Mean wind velocity about 4m/s.

Common Dwellings:

Detached single or two-storey houses. Timber frame constructions with brick or concrete underslab or basement. High-rise apartments and rows of houses in suburban areas, usually brick or concrete.

Mean air leakage value about 11 ach at 50 Pa for conventional houses and 6 ach at 50 Pa for energy efficient houses.

Ventilation Problems:

Radon, formaldehyde, combustion gases of unvented appliances and condensation in the building structure.

Appendix B: Review of Common and Advanced Ventilation Systems

Category 1: Air Movement Control Systems

1.1 Spot Flow Control Systems

- 1.1.1 Local Exhaust Systems
- 1.1.2 Jet Flow Systems
- 1.1.3 Enforced Local Exhaust Systems
- 1.1.4 Localised Ventilation Systems

1.2 Internal Roomflow Control Systems

- 1.2.1 Mixing Ventilation Room Systems
- 1.2.2 Displacement Ventilation System
- 1.2.3 Forced Vortex Ventilation System

1.3 Inter-Room Flow Control Systems

- 1.3.1 Natural Exhaust Duct System with Controlled Supply
- 1.3.2 Mechanical Exhaust/Controlled Supply Systems
- 1.3.3 Mechanical Supply Systems
- 1.3.4 Mechanical Supply and Exhaust Systems
- 1.3.5 Overflow Ventilation Systems

1.4 Dwelling in or Outflow Control Systems

- 1.4.1 Radon or Methane Mitigation Systems
- 1.4.2 Vapour Mitigation Systems
- 1.4.3 Combustion Ventilation Systems

Category 2: Flow Quantity Control Systems

2.1 Automatic Set-Point Maintenance Systems

- 2.1.1 Temperature Controlled Natural Supply System
- 2.1.2 Pressure Difference Controlled Natural Supply Systems
- 2.1.3 Pressure Difference Controlled Mechanical Ventilation

2.2 Automatic Setpoint Adjustment Systems

- 2.2.1 Presence Dependent Mechanical Ventilation
- 2.2.2 Carbon Dioxide and Odour Controlled Ventilation
- 2.2.3 Humidity Controlled Ventilation
- 2.2.4 Temperature Controlled Ventilation

Category 3: Ventilation Heat Recovery Systems

- 3.1 Air-to-air Heat Recovery
- 3.2 Air to Heat Pump Systems
- 3.3 Heat Recovery Air Supply Windows
- 3.4 Dynamic Wall Heat Recovery

Category 4: Alternative Ventilation Energy Gain Systems

- 4.1 Soil-Heated or Cooled Ventilation Air
- 4.2 Solar Heated Ventilation Air

APPENDIX B

REVIEW OF COMMON AND ADVANCED VENTILATION SYSTEMS

Category 1: Air Movement Control Systems

1.1 Spot Flow Control Systems

1.1.1 Local Exhaust Systems

Objective:

Direction and capture of pollution near the source.

Description:

A pollutant flow is directed into the exhaust system using either or both (Fig.1):

- a well-shaped exhaust hood placed down stream of the freely flowing pollutant.
- a velocity field created by the exhaust flow dominating the local pollutant flow.

To capture all pollutants the exhaust flow has to be as large as the pollutant production increased with the induced airflow.

The exhaust system ducts the polluted air straight to the outside or via air cleaning devices to the outside or back into the room

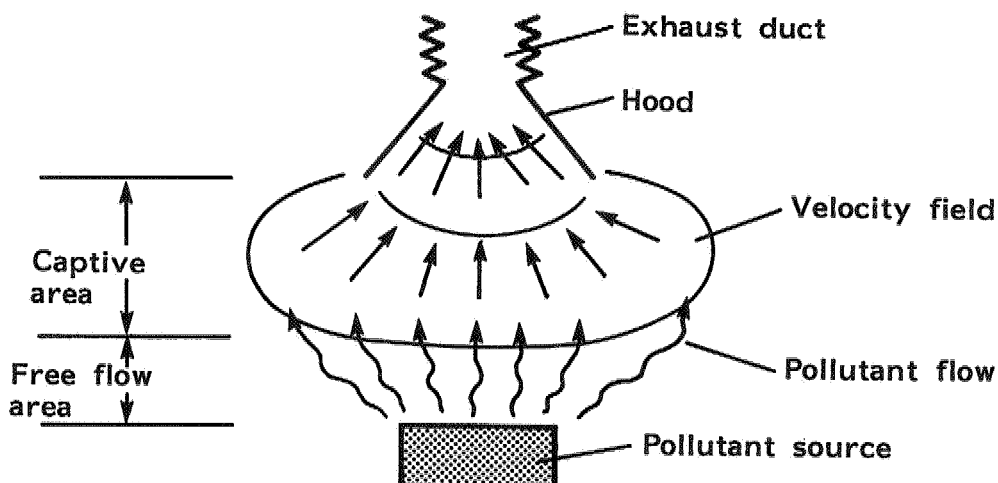

Figure 1: Principle of Local Exhaust

Applications:

Cooking equipment and combustion appliances in dwellings. Widely used in industrial processes.

Properties:

- * The capture efficiency of the system is very much restricted to the location of the exhaust opening. This does not allow moveable sources of pollution, unless moveable exhaust devices are used.
- * The capture efficiency of the system is also easily affected by variations of the production or flow direction of pollutants, as well as by accidental air movements caused by moving people, open windows, supply grilles, etc. Hence correction of these effects needs a large over-dimensioning of the exhaust flow.
- * Immediate local exhaust of high productive intermittent sources needs relatively large temporary flows compared to the continuous flow of a dilution ventilation system. This is due to the lack of an air buffer to accumulate the temporary production of the pollutant. The advantage is that the total volume of replaced air with the local exhaust may be an order of magnitude lower than with the dilution ventilation system. This allows energy conservation. However, the disadvantage may be in the temporary high supply flows possibly causing draughts. To prevent this problem special supply provisions and the use of preheated supply air may be advisable. This may increase the complexity and the cost of the system. Also the correct dimensioning of the supply flow is important to prevent depressurization effects.
- * The residential application of different local exhausts means decentralized ventilation ducts, which hinders the application of central provisions such as heat recovery and air cleaning.

Benefits:

- * Local exhaust high concentrations, low air volumes cause a significant reduction of the total exchanged air volume compared to dilution ventilation (low concentrations due to exposure, high air volumes). Reductions may easily be by a factor of 10 or more, thus allowing comparable reductions of the energy demand. At the same time the indoor air quality is improved.
- * Local ventilation allows an optimal adjustment to local demands. This prevents unnecessary ventilation of unpolluted rooms when ventilating polluted rooms connected to the same centralized system.
- * Local ventilation systems can be applied in combination with other systems such as displacement ventilation systems.

- * The principle extraction of high concentrations in low air volume flows answers a basic condition for high efficiency air cleaning.

References:

AIRBASE Nr.1627, 1756, 2750 and 3219

1.1.2 Jet Flow Systems

Objective:

Direction of pollutant flows and separation of inter-room zones.

Description:

Air is supplied to a room via nozzles or slits in a specified direction, thereby inducing a controlled local movement of the room air (Fig.2). The system is often used in combination with a local exhaust located downstream of the major airflow.

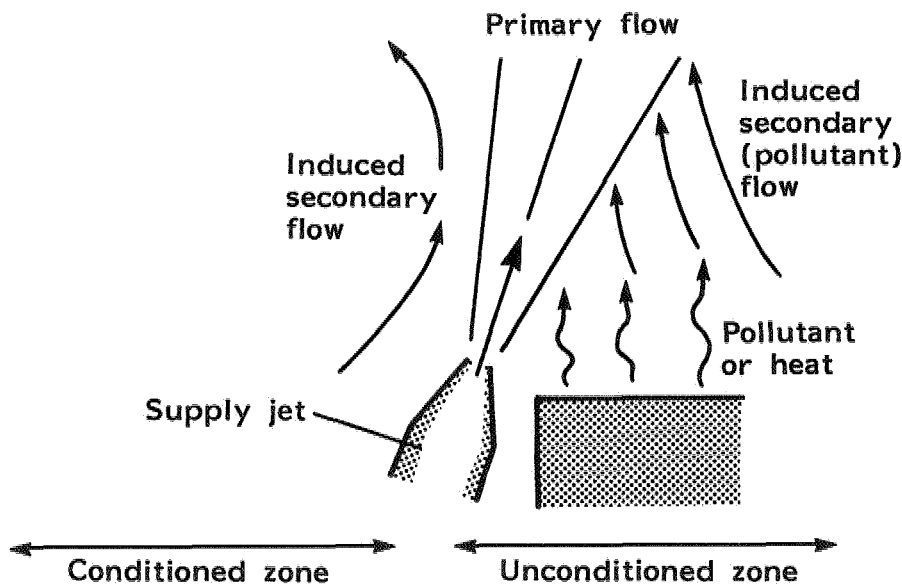

Figure 2: Principle of Jet Flow

Applications:

In industrial processes and utility buildings to direct a pollutant flow into the exhaust (e.g., open surface solvent baths), to separate a conditioned and unconditioned zone.

Properties:

- * Needs auxiliary exhaust to capture a directed pollutant flow.
- * Critical design, in general, experimental while no design rules are available.
- * Interaction with obstacles and heat sources.
- * Creates turbulence which causes some air exchange between conditioned and unconditioned zone.
- * High primary supply velocities can cause local discomfort and noise.

Benefits:

- * Good control of flow directions with relatively small air volume flows (jet flows of approximately 5% of the exhaust flows).

References:

-

1.1.3 Enforced Local Exhaust Systems

Objective:

Improved direction and capture of pollutants near the source.

Description:

The systems are in principle combinations of local exhaust (1.1.1) and jet flow systems (1.1.2), with the distinction that they are integrated in one device. They create vortices near the exhaust deforming the exhaust velocity field from a unidirectional global one into an enlarged single directional one (Fig.3). A spiral shaped exhaust velocity field shows the best results.

Applications:

Some industrial processes.

Properties:

See 1.1.1, local exhaust systems, except for the capture efficiency being less restricted to the location of the exhaust.

Benefits:

See 1.1.1.

References:

AIRBASE Nr.2212, 2750, and 3393.

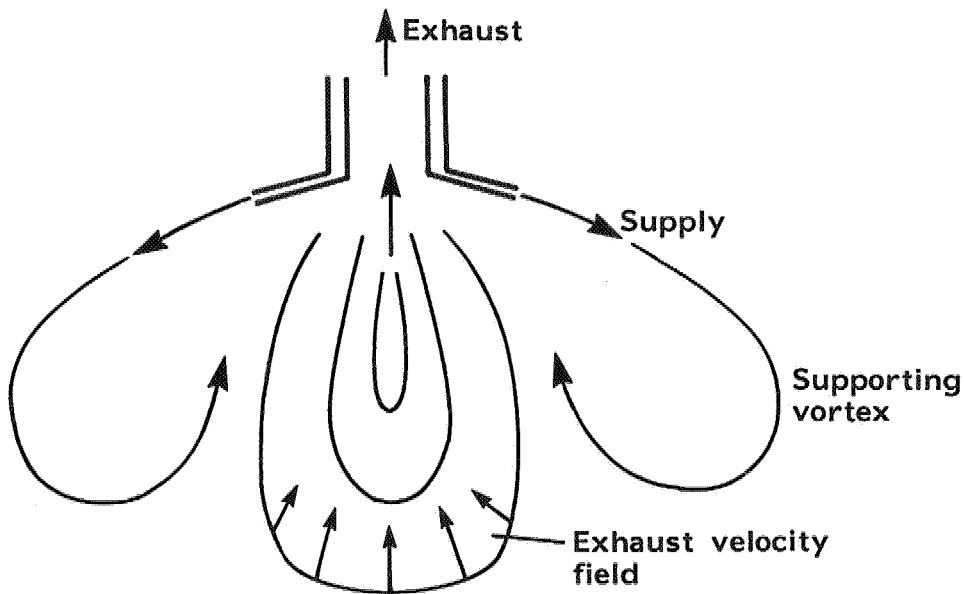

Figure 3: Principle of Enforced Local Exhaust

1.1.4 Localised Ventilation Systems

Objective:

Local ventilation of a room zone.

Description:

Conditioned ventilation air is supplied directly to an occupied zone of a partially unconditioned or different conditioned room (Fig.4 over). The supply devices uniformly distribute the air into the occupied zone, to create an acceptable local air quality and/or climate. Exhaust of air may be in or out of the occupied zone, both central or local. In general the supply in each zone is operated at occupancy, whilst the exhaust flow is balanced to the total supply flow.

Applications:

Large office rooms, theatres, industrial environments controversial to occupants' needs (e.g., meat processing plants), hospitals (operating room zone climatisation).

Properties:

- * Air supply directly to occupied zones needs a proper distribution and preheating of supply air to prevent discomfort.

- * Separate local supply provisions further the complexity of the system, especially when automatically occupancy controlled.

Benefits:

- * Restriction of ventilation and/or air conditioning to occupied zones only, reduces energy demands.
- * Localized ventilation enables different environments in one room, allowing optimal conditions for both processes and occupants.

References:

AIRBASE Nr.3219.

Papers to the 11th AIVC Conference by E A Arens et al., Lawrence Berkeley Univ., California.

DERWENT, access Nr.86-338484.

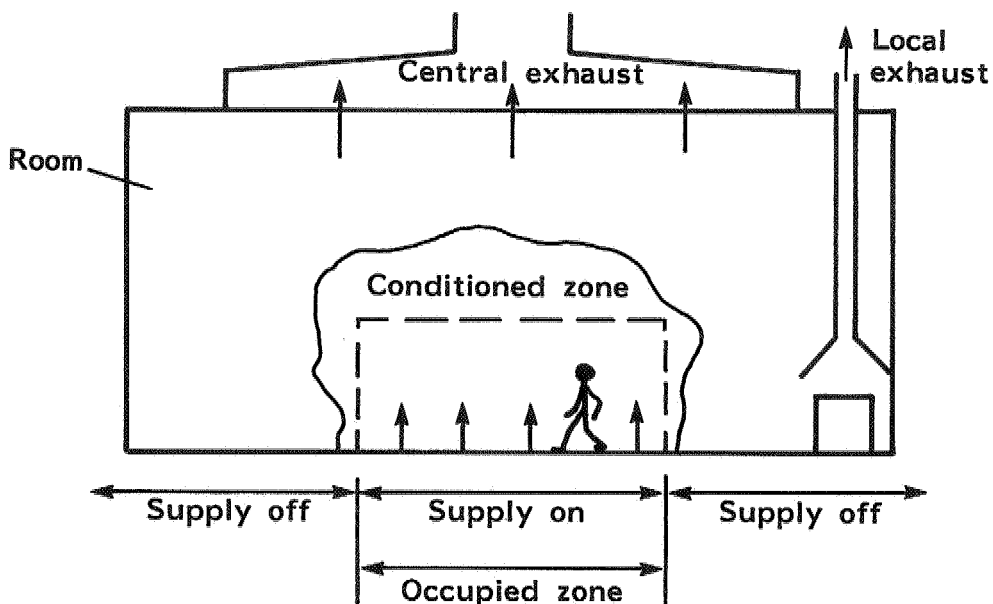

Figure 4: Principle of Localized Ventilation

1.2 Internal Roomflow Control Systems

1.2.1 Mixing Ventilation Room Systems

Objective:

Dilution of polluted room air by clean air.

Description:

Pollutants are mixed within the room air and kept at an acceptable level by mixing them with clean air. Mixing is generated by all kinds of air movements caused not only by supplied clean air, but also by the pollutant source, moving objects, local temperature differences, etc. (Fig.5). It does not need defined flow directions and velocities. This means mixing ventilation can occur with practically all kinds of ventilation devices. However, proper mixing does depend on:

- the distribution of ventilation air,
- the interaction of supplied airflows with room airflows,
- the location of exhausts relative to supply-openings (possible short circuiting).

Because of the possibility of mixing ventilation with more or less undefined supply and exhaust properties, uncontrolled or manual controlled natural and mechanical ventilation are widely applied. In general these systems do not fit in this category because the flows are not restricted to one room (central systems), though some kind of flow quantity control per room may be applied (see Category 2).

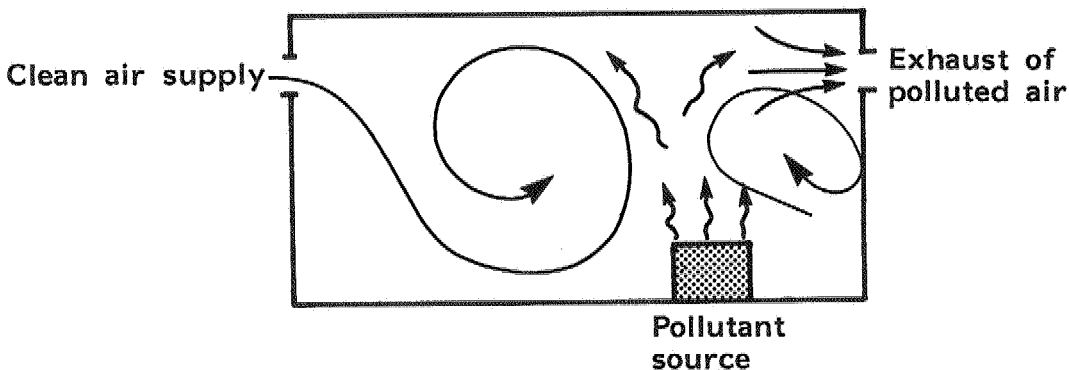

Figure 5: Mixing Ventilation Is Caused By Internal Air Movements.

A few papers refer to room ventilation units (decentral systems). These units provide a controllable mechanical supply and exhaust per room, with or without air to air heat recovery (Fig. 6).

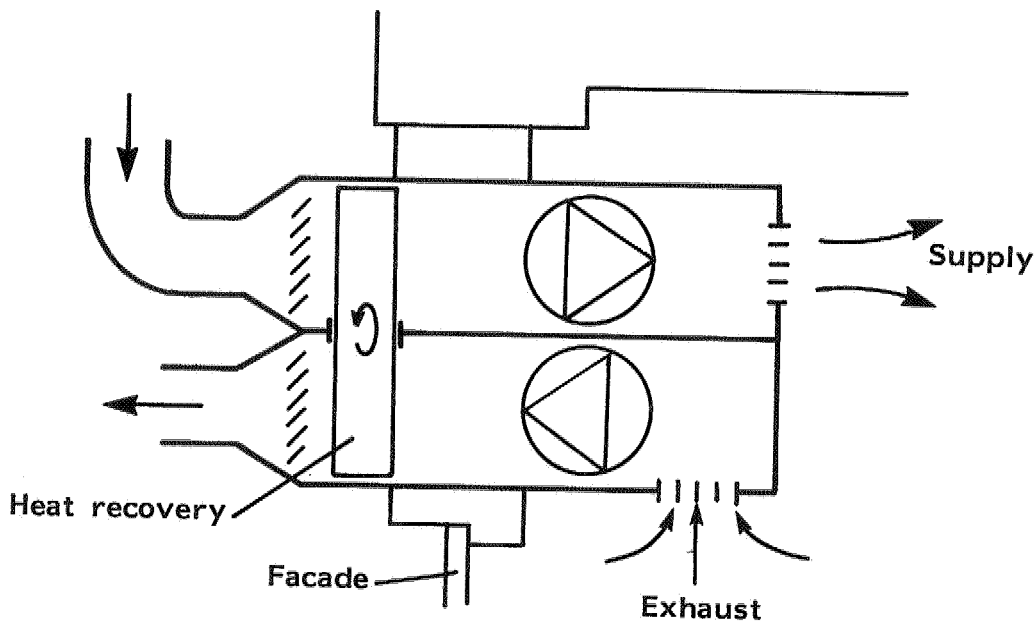

Figure 6: Unit For Room Ventilation

Applications:

Decentral systems are applied in industrial premises as well as in German dwellings, the latter combined with cooling.

Properties:

- * Air supply directly to occupied rooms needs a proper distribution and preferably preheating to prevent discomfort.
- * Good sound insulation required to prevent noise during operation.
- * Possibility of short circuiting of ventilation air when combined supply and exhaust units are applied.
- * Total costs of x room units are expected to be higher than one central ventilation system per dwelling.

Benefits:

- * Independent ventilation per room is possible with optimal adjustment to local needs and no unnecessary operation in unoccupied rooms.
- * Local room ventilation allows the quick removal of pollutants from a source-room, before they mix up with the air in other rooms as might happen with central dwelling ventilation. This reduces the total ventilation air volume

and the related energy consumption, as well as the total doses of exposure to pollutants.

- * Control per room allows easy and optimal compensation for local disturbances by wind, occupants, etc.
- * Wall-mounted local ventilation units do not need any ducting within the dwelling and are suitable for retrofit use.

References:

AIRBASE Nr.1704.

DERWENT access nrs.82-B0559E and 84-248427.

1.2.2 Displacement Ventilation Systems

Objective:

Create mixing ventilation with a tendency to unidirectional flow of pollutants away from occupants.

Description:

Buoyancy effects of human sources and other warm sources cause most pollutants to rise. If this stratification is allowed to continue, rather than be impaired by the ventilation system, the ventilation efficiency of polluted or occupied zones can be increased without increasing overall ventilation (Figure 7).

In general this means a low-velocity, fresh air supply near the floor into the occupied zone, with temperatures slightly below the local air temperatures. Though vertical flow through the floor is possible, horizontal supply through wall diffusers, using filter clothing or perforated panels, is found to be most practical. The exhaust provisions are located near the ceiling, preferably close to pollutant sources.

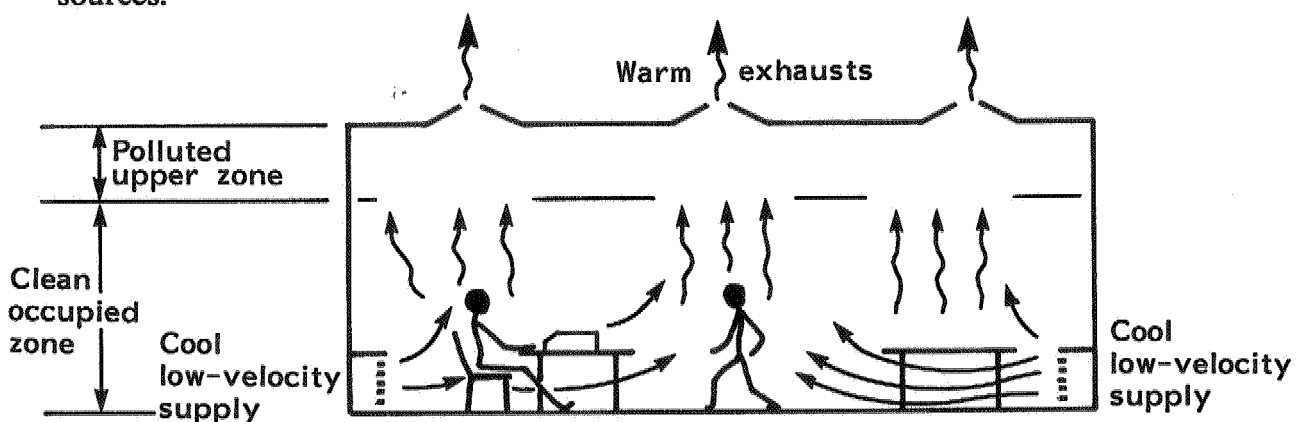

Figure 7: Principle Of Displacement Ventilation

Applications:

Offices and industrial premises with heat sources (as yet on a limited scale, but rapidly growing).

Properties:

- * Creating a displacement flow needs a good distribution of cool supply air (up to 5K below room temperature) with low supply velocities (below the upper comfort limit).
- * The displacement effect, expressed in the ventilation efficiency, decreases with the distance from the supply openings. In practice the effect is restricted in height.
- * Displacement flow does not alter greatly over a wide range of supply airflow rates. Generally the ventilation efficiency is increasing with the airflow, but so is local discomfort.
- * Upward displacement flow can only be maintained with supply temperatures below the temperature of the room air. The ventilation efficiency as well as local discomfort are increasing with the temperature difference.
- * Stratification in displacement flow leads to relatively high exhaust temperatures, compared to mixing ventilation. In summer the cooling capacity of ventilation air therefore is relatively higher. However, in winter a higher energy loss is caused by this, reducing the advantage of a higher ventilation efficiency. Nevertheless, the overall temperature efficiency in a well designed displacement system will still be better.
- * According to most researchers, displacement ventilation needs relatively high flow rates of up to 3 or 4 times the basic demand (about $1.4 \text{ dm}^3/\text{s.m}^2$ floor area, without recirculation is an indicative rate). A way to maintain displacement flow at low ventilation demands is to eject large flows of room air into the primary ventilation air. Generally this will smooth out temperature differences, thereby decreasing both local discomfort and ventilation efficiency. This is also known as "low velocity ventilation".
- * The restricted proportions of displacement ventilation make the system less suitable for the removal of large heat loads. The ability to remove heat increases with the height of the supply openings, but also the costs.
- * Convective flows, induced by local solar radiation or panel heaters, impair stratification causing reduced ventilation efficiency.
- * Persons moving around, occasionally opening doors, only appear to have a small effect on ventilation efficiency. On the other hand high occupancy load

of non-moving persons increases ventilation efficiency. The ventilation efficiency of partly occupied rooms very much depends on the location of occupants.

- * The interaction of the displacement system with interior surfaces of different temperatures suggests the application in well-insulated buildings with a uniform heat distribution. Combined heating and ventilation systems are not suitable.
- * The design procedure of a displacement ventilation system has to account for obstacles and the main contaminant flows and heat flows to create the most favourable flow pattern. It means the system might be less suitable for flexible room applications.
- * The creation and maintenance of a stratified flow makes the displacement ventilation system less suitable for highly dynamic situations.
- * Possible pick up of contaminants from the floor.

Benefits:

- * Improvement of the ventilation efficiency compared to mixing ventilation systems, resulting in a superior air quality and/or energy conservation up to about 20% in practical applications.
- * Both the displacement flow and the properties of the supply provisions allow a wide variation of the supply flow rate. This makes the system suitable for demand control.

References:

AIRBASE Nr's 985, 1626, 2121, 2227, 2236, 2302, 2472, 2610, 2611, 2612, 2649, 2845, 3120, 3219, 3525, 3527, 3529, 3577, 3612 and 3719.
DERWENT access Nr's 82-D4665E and 85-056882.



1.2.3 Forced Vortex Ventilation Systems

Objective:

Create dominating vortex flows to control pollutant flows and to provide clean air.

Description:

Ventilation air is supplied via vertical grills on the same side of each wall, near the corners of a room. The high supply velocities induce a main vortex-shaped flow of room air, dominating normally existing natural room air flows. An exhaust opening is installed in the centre of the ceiling. The combination of the

vortex and the central exhaust throttles the used air into the exhaust (Figure 8) . The vortex highly reduces the dispersion of contaminants from the room to surrounding places.

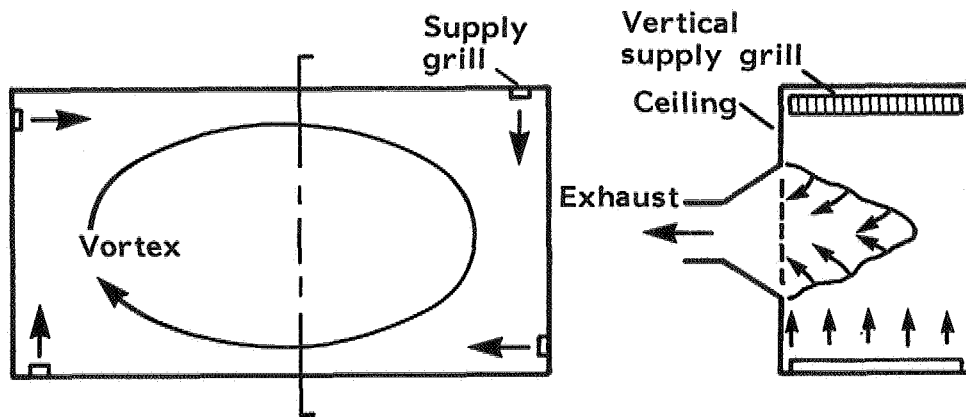

Figure 8: Principle of A Forced Vortex Ventilation System

Applications:

Airlocks at building entrances.

Properties:

- * Dominating natural room flows rather than using them suggests high energy demands.
- * High control velocities in the vortex may cause draughts.
- * System performance impaired by obstacles.

Benefits:

- * Prevents the dispersion of contaminants beyond the vortex boundary.
- * System performance hardly influenced by the heating system, internal heat loads, variations of supply and room temperature, opening of doors, etc.

References:

AIRBASE nr's 3219 and 3393.

1.3 Inter-Room Flow Control Systems

1.3.1 Natural Exhaust Duct System With Controlled Supply

Objective:

Create a main flow from outside into habitable rooms which overflow to service rooms before being exhausted.

Description:

Vertical ducts, applied to service rooms, create exhaust flows, based on the stack-effect occurring during the energy consuming heating season. The air is supplied through vents in the walls of habitable rooms on different orientations. Normally the leeward-side wall vents turn into exhausts by occurring cross-ventilation at higher wind velocities. The system is based on preventing this cross-ventilation under most conditions, thus maintaining supply to habitable rooms, overflowing to service rooms to be exhausted. This needs:

- (i) location of the outlets of exhaust ducts in the centre of the roof (location with lowest wind pressures);
- (ii) airtight buildings, having air leakage values under 5 ach at 50Pa;
- (iii) a relatively large opening area of the exhaust ducts compared to the maximum opening area of the supply vents;
- (iv) control of supply-vents to restrict the maximum flow rate per vent, especially concerning the windward side supply vents (see also Category 2.1).

To get an overflow of air from supply rooms to exhaust rooms a certain level of air leakage for inside-walls is necessary. The opening areas of these overflow provisions have to be restricted. The inter-room flows cannot be controlled with large openings like open doors. They will exchange air flow rates per door in the order of magnitude of 10 or more times the total basic flow. Hence, inter-rooms control of basic flows requires closed inner doors.

Applications:

Dwellings, schools, small office buildings , animal shelters.

Properties:

- * Both the inter-room flow directions and quantities are dependent on the weather conditions. Control of the supply provisions can strongly reduce this dependancy but not completely eliminate it. Only a continuous automatic

control is thought to be sufficient, due to the complex relations involved. What's more, this control is strongly hindered by wind fluctuations.

- * Inter-room flow control strongly depends on the occupants' behaviour concerning the use of doors and additional ventilation provisions.
- * Vertical exhaust ducts, especially with large opening areas as in natural ventilation systems are a limiting factor in the building design.
- * The decentral supply and exhaust does not allow the application of heat recovery. The low system pressures do not even allow the use of a heat pump recovering heat from the exhaust air.

Benefits:

- * The natural ventilation system can operate without auxiliary energy.
- * The basic provisions of the natural ventilation system may be simple.
- * The basic system has no noise generating parts.
- * The system fits into present traditions, which eases the introduction of advanced versions.

References:

AIRBASE nr's 2588, 3027, and 3741.
Report Nr R88/049 of MTTNO, Holland.

1.3.2 Mechanical Exhaust/Controlled Supply Systems

Objective:

See 1.3.1

Description:

The system is a variety of the natural one (1.3.1). It is less dependent on the stack effect and less critical on wind-conditions by using a mechanical exhaust fan. However, because a large depressurization of the dwelling is not desirable, the flows per room with fixed wall-vents are still not completely dominated by the fan. Particularly leeward-side rooms may be strongly under ventilated. To prevent this the control of the maximum supply flow per wall-vent is still required (see Category 2.1). When using one central exhaust fan for a number of exhausts in one or more dwellings, the exhaust per room might differ from the set-points in other rooms connected to the system. In this case also a flow control on the exhaust might be desirable (see also Category 2.1).

Applications:
Dwellings.

Properties:

- * A continuous automatic control of the supply vents is needed to ensure adequate flows of outside air that would otherwise vary according to the prevailing weather conditions.
- * Inter-room flow control strongly depends on the occupants' behaviour concerning the use of doors and additional ventilation provisions.
- * Vertical exhaust ducts, although often small in a mechanical system, might be a limiting factor in the building design.
- * The decentral supply does not allow the application of an air-to-air heat recovery system.
- * The system needs auxiliary energy for fans.
- * The system might generate noise.

Benefits:

- * The system fits into present traditions which eases the introduction of advanced versions. Air flow variations are not so critical as with a natural ventilation system and the application of a heat pump recovery system on the exhaust air is an option. This system can be used in retrofitting.

References:

AIRBASE Nr's 764 and 2319.
IBSEDEX Nr. 8100786.
References of Category 1.3.1 and 2.1.

1.3.3 Mechanical Supply Systems

Objective
See 1.3.1.

Description

Local fans or terminal devices of a ducting system with a central fan supply fresh air or a mixture of fresh air and recirculated air to habitable rooms. the supplied air is allowed to overflow via inner walls the service rooms, to be exhausted naturally.

Applications

Not applied in dwellings.

Properties

- * The supply to habitable rooms will not only create an overflow on inner walls, but also exfiltration through the outside walls. This causes a high condensation risk in outside walls.

Benefits

- * The system is able to create overpressure in the dwelling thus preventing unwanted infiltration, e.g. of air containing radon from the soil.

References

-

1.3.4 Mechanical Supply and Exhaust Systems

Objective:

See 1.3.1.

Description:

Outside air is supplied to habitable rooms by a fan and a duct provided with supply terminals. Used air is exhausted from service rooms by exhaust grills via a duct and a fan to the outside.

The next varieties of the system may occur as follows:

- (i) **Unbalanced Flows.** Usually the supply is about 80% of the exhaust flow to allow a better control of the complementary infiltration. On special occasions the opposite system (exhaust 80% of supply) may be applied, e.g. in dwellings with radon problems, although this system has an increased condensation risk by exfiltrating indoor air;
- (ii) **Heat Recovery.** Air-to-air heat recovery between exhaust and supply air may be used, both to reduce the ventilation energy demand and to preheat the supply air, reducing draughts;
- (iii) **Air Heating.** Because of the general system appliance in airtight, well-insulated dwellings the heating demands are reduced. This allows the combination of air heating and ventilation, thus reducing total system costs.
- (iv) **Recirculation.** Supply air may be a mixture of clean outside air and recirculated indoor air, either to increase the total airflow for heat transport. Often the fans can be operated at varying speeds to provide adjustment to

different ventilation or heating demands. However, flow control for separate rooms is not common.

Applications:

Dwellings, offices, schools.

Properties:

- * Even with partly unbalanced flows the infiltration losses are not reduced significantly, so the building has to be airtight.
- * This type of system normally does not have independent room flow control.
- * Recirculation causes the spread of pollutants out of rooms, where the recirculated air has been extracted, through the whole house. On the other hand it causes the levelling of room concentrations, using the total amount of ventilation air.
- * Airflow rates demanded for heat transport differ from the ventilation flow rates. Without high recirculation rates this may cause over or under ventilated rooms.
- * The combination with air heating does not allow the combination with displacement ventilation.
- * The balance of supply and exhaust flow is affected by varying temperature differences between inside and outside.
- * The system needs auxiliary energy for the fans.

Benefits:

- * The mechanical supply and exhaust allow a good control of the flows towards and between rooms, the latter mainly with doors closed.
- * The system allows the use of air-to-air heat recovery.
- * The system might be combined with air heating, thus reducing total installation costs and the demands on the supply-provisions.

References:

AIRBASE Nr.2309 and 3129

DERWENT access nr.86-106696.

1.3.5 Overflow Ventilation Systems

Objective:

Create defined flow directions between rooms, even with open doors or unfavourable weather conditions.

Description:

Rooms are provided with either or both mechanical supply or mechanical exhaust. The flows per room are established in a way that a hierarchical pressure-order is reached, creating the highest pressures in the cleanest rooms and the lowest pressures in the most polluted service-rooms. The flow differences per room are allowed to overflow from clean rooms via rooms with lower pressures to the polluted rooms by restricted openings in indoor walls. Though the flow quantities might be affected by opening doors or by fluctuating infiltration, the flow directions will be maintained. The system allows rooms to be partly or totally ventilated with wasted air from rooms with a higher pressure level.

Applications:

Hospitals, clean rooms, and restaurants.

Properties:

- * The system needs total ventilation flows very much exceeding basic ventilation needs for occupants.

Benefits:

- * The system is able to control the flow-directions between rooms in a wide range of circumstances, thus preventing unfavourable pollutants-transport.
- * The total airflow through a building with an overflow ventilation system is a few times smaller than the total airflow in a traditional system with parallel flows.

References:

AIRBASE Nr.1254.

1.4 Dwelling in or Outflow Control Systems

[Note: Because this category of systems deals with additional ventilation needs which are not the subject of this study, the systems are not extensively described]

1.4.1 Radon or Methane Mitigation Systems

Objective:

Reduce a radon or methane containing airflow from the soil to the dwelling.

Description:

In certain areas severe methane or radon and radon progeny emittance from the soil to the building may occur. Air leakage of the house, in particular of the floor, with the stack-effect as a driving force are the important factors in the transport, also influenced by the ventilation system. Sealing measures may reduce indoor concentrations up to 65%. Depressurization of a gravel bed beyond the slab, via suction pipes, an exhaust fan and ducting to the outside, shows a reduction of about 90%. The performance of this system is impaired by its increase of the soil emission up to ten times. Because the opposite occurs with subslab pressurization, this system, in combination with a sealed floor may show comparable reductions of indoor concentrations, when applied to permeable soils.

Applications:

Dwellings on soils with high methane or radon emittance.

Properties:

- * Subslab depressurization may increase the infiltration of the dwelling. Sealing measures may reduce the infiltration. Subslab pressurization would not affect the infiltration energy losses too much when using the exhaust air of the dwelling.

Benefits:

- * Reduction of indoor air concentrations of radon, radon progeny or methane.

References:

AIRBASE Nrs.273, 539, 1173, 1630, 1865, 2067, 2290, 2792, 3252, 3426, 3437, 3560, 3695 and 3744.

1.4.2 Vapour Mitigation Systems

[Note: In colder climates, unfavourable vapour transports through the building envelope are generally sufficiently reduced by constructive measures like airtightening, application of vapour barriers, a concrete subslab construction, etc. Complementary depressurization by the ventilation system may be favourable. One paper is found dealing with the application of a natural exhaust duct on a crawlspace (AIRBASE Nr.3328)]

1.4.3 Combustion Ventilation Systems

[Note: The exhaust of combustion gasses and the supply of combustion air is often dealt with in special requirements. In most countries the application of large open fire combustion apparatus within occupied spaces is prohibited. In Japan where local combustion appliances in occupied spaces are common, ventilation requirements are based on it. The general trend is to put combustion apparatus in separated, specially ventilated rooms, or to use combustion apparatus with its own closed ventilation circuit.

In the first case interactions with the ventilation system of the dwelling still may appear, such as backdraughting when a mechanical exhaust only system in an airtight dwelling is applied. Consideration may also be given to the possibility of heat recovery from combustion gasses to ventilation air.]

Category 2: Flow Quantity Control Systems

2.1 Automatic Set-Point Maintenance Systems

2.1.1 Temperature Controlled Natural Supply System

Objective:

Provide a constant supply flow at varying outside temperatures in thermal buoyancy dominated ventilation systems.

Description:

In cold climates especially in high rise buildings with vertical exhaust ducts, the ventilation flows are very much affected by the varying thermal buoyancy effects. Even with mechanical exhaust a flow increase of 50% is not rare. This caused the development of a system, compensating for the variation of the thermal driving forces, by decreasing the opening areas of the supply vents with decreasing outside temperature. Therefore each supply vent is provided with a restricting valve, operated by a bimetallic spring, primarily exposed to the cold incoming airflow and to some extent to the indoor air (Fig.9 over). The restricted sensibility to indoor air causes the control mechanism also to react on variations of the rate of incoming air, thus compensating for some wind variations.

Applications:

Incidentally in dwellings in cold climates, with natural supply.

Properties:

- * The system does not control ventilation in mild weather conditions. Since the stack-effect reduces with higher outside temperatures, this may lead to an under ventilated dwelling during the periods with the highest vapour loads (spring and autumn). This may be compensated by the traditional behaviour of increased window opening in mild weather conditions or by an auxiliary low-pressure exhaust fan.
- * The system is still wind dependant. The largest flow variation is to be expected per separate room, rather than on the whole dwelling, due to variation of the wind direction. Since the largest flow-variations will occur during higher outside temperatures, the energetic consequence will be moderate. The wind-dependency still may cause draughts near the inlets, also because of a limited wind fluctuations damping function.

- * The vents are not pre-adjustable to differences in wind-attack per location, to differences in air leakage of the building or to differences in stack-effect with different heights of the exhaust ducts.
- * The vents are not adjustable to different ventilation demands.

Benefits:

- * The temperature control diminishes overshoot of the ventilation flow, thus saving energy and reducing draughts near the air inlets.
- * The flow directions are better controlled because of the reduction of reversing flows due to cross-ventilation.
- * The system operates with low-cost provisions.
- * The system is suitable for retrofit-use.

References:

AIRBASE Nr.764 and 2588.

IBSEDEX access nr. 8100786.

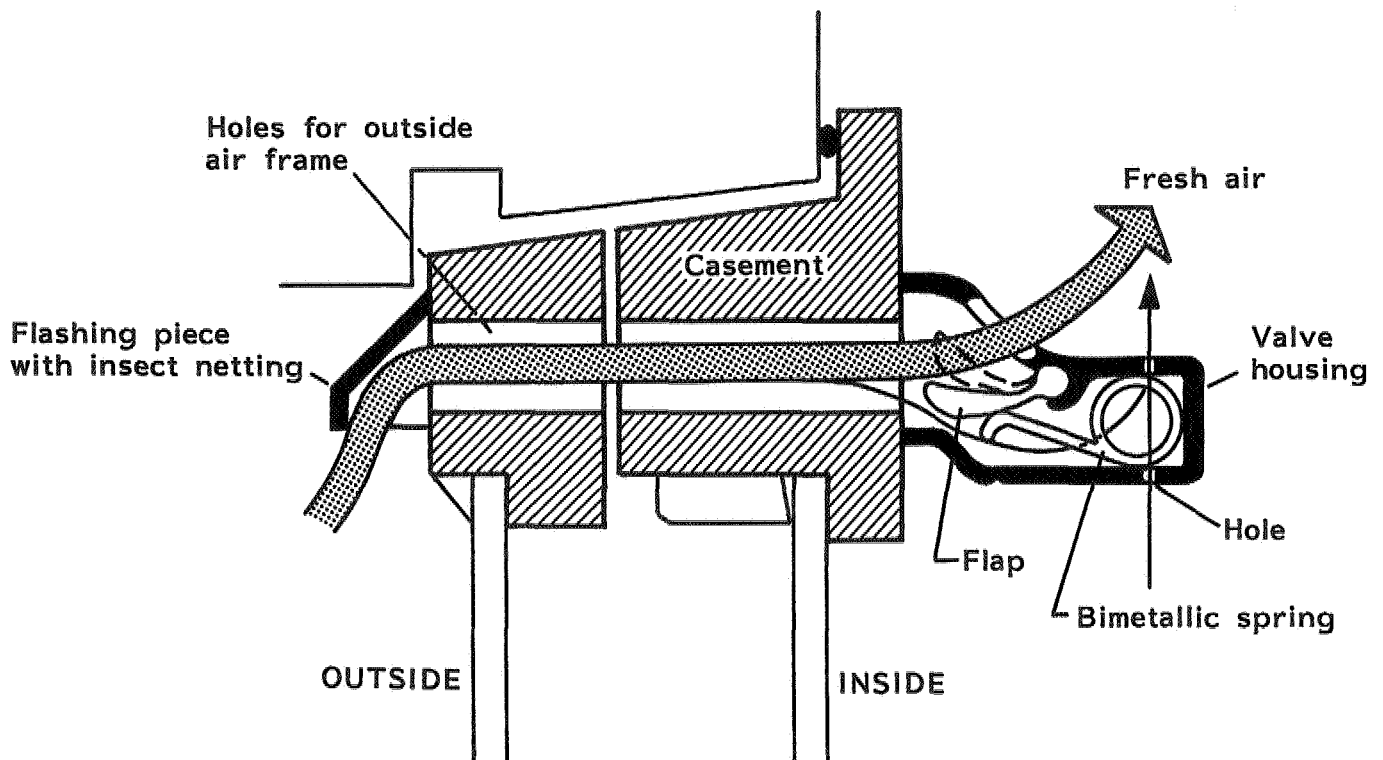

Figure 9. Automatic Temperature Controlled Inlet Terminal

2.1.2 Pressure Difference Controlled Natural Supply Systems

Objective:

Provide a constant natural supply flow, independent of wind and outside temperature variations.

Description:

Variations of the wind and the outside temperature are known to have a large impact on the ventilation flows. The flow through a fixed inlet-opening may show a large variation and even reversion, especially in natural ventilation systems, but also to some extent in mechanical exhaust systems. It makes systems unreliable and difficult to control by the occupants. By automatically adjusting the inlet-opening to the varying local pressure difference a constant flow can be realised (Fig.10). It appears that by controlling the supply flows, even flow-reversion due to cross-ventilation at different wind directions may be restricted to exceptional weather conditions (see also Category 1.3.1). The control mechanism of the supply-vents is allowed to operate without auxiliary energy, using the variations of the pressure difference over the area of the flow restricting valve as an adjusting force. In its most advanced version the supply vents are able to compensate for infiltration losses by decreasing their supply flow with increasing pressure differences.

The vents are also openable, closeable and adjustable to different basic ventilation demands.

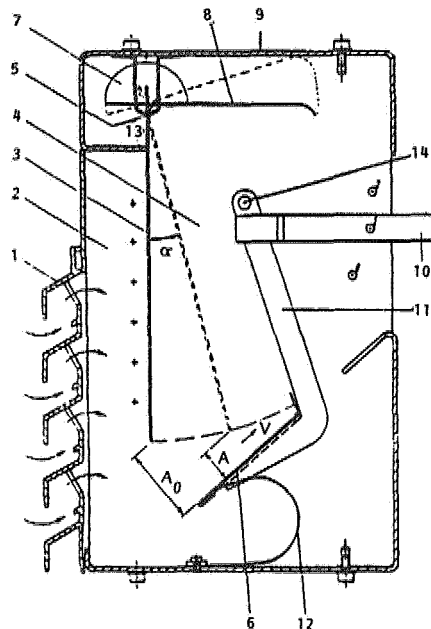

Figure 10a: Principle of automatic supply control. Increasing pressure differences allow movement of valve (3), restricting the opening area A

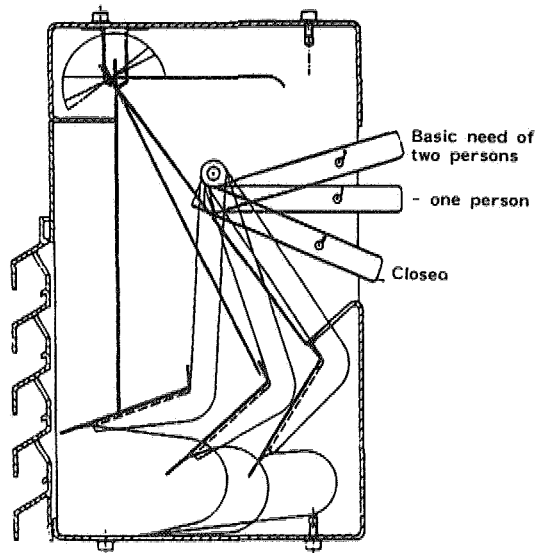

Figure 10b: The three basic positions of the flow adjustment portion.

Application:

Dwellings with natural supply.

Properties:

- * Control of natural supply openings needs very sensitive devices able to operate at very low pressure differences, ranging from about 0.5 to 50 Pa. This asks for provisions with a large controlling valve, low friction losses of moveable parts and a good cleanability to prevent disfunction. Hence, the device needs a damping mechanism to prevent clacking of the control valve due to fluctuating pressure differences.

Benefits:

- * Provides constant ventilation, independent of variable weather conditions also improving the control of the flow directions.
- * Pre-adjustable to compensate infiltration in dwellings with different airtightness.
- * Reproduceable and reliable setpoints, adjustable from closed to different basic ventilation demands.
- * No auxiliary energy demands for the operation of the system.

References:

AIRBASE Nr. 764 and 3741.

Report R88/322 of MT-TNO Holland. Commercial documentation of BUVAMATIC-Holland, INTERVENT-Holland and AMERICAN-ALDES-USA.

2.1.3 Pressure Difference Controlled Mechanical Ventilation

Objective:

Provide a constant mechanical ventilation independent of variable system pressures.

Description:

The flow through grilles or ducts of a mechanical ventilation system may vary due to:

- (i) wind or stack-effects and opening windows and doors;
- (ii) control measures on other system connected provisions;
- (iii) fouling of grilles;
- (iv) improper pre-adjustment of the system components.

Using pressure-differences controlled supply terminals, exhaust terminals or duct valves constant flows will occur independent of the pressure variations in the system.

In general the controlled provisions do have a moveable portion connected to a static part via a metallic spring, a silicone bulb, bellows or comparable parts. The moveable portion is actuated by a variation of the local pressure-difference, allowing it to reach a new equilibrium stage thus adjusting the flow restricting opening area (Fig.11). This type of flow adjustment needs no auxiliary energy. Common pressure-ranges are between 20 and 250 Pa for constant flows between 5 and 120 dm³/s.

Application:

Mechanical ventilation systems of flats and offices.

Properties:

- * In principal the system does not allow flow adjustment to different demands. High/low fan control will be (partly) compensated, depending on the control range of the provisions. Just a few provisions do have a high/low adjustment of their own. This will need a continuous high speed fan operation, possibly linked with high noise levels.

Benefits:

- * Provides a constant mechanical flow, independent of disturbances.
- * Needs no pre-adjustment to building and system properties, which means a short installation duration.
- * Allows cheaper ductwork in high-rise buildings, applied to a higher number of storeys, at the same time using a fan with a lower total static pressure and avoiding high terminal pressure differences.
- * Suitable for retrofit-use.

References

AIRBASE Nr.2319.

Commercial documentation of AMERICAN-ALDES-USA,
INTERVENT-Holland and LINDAB-UK.

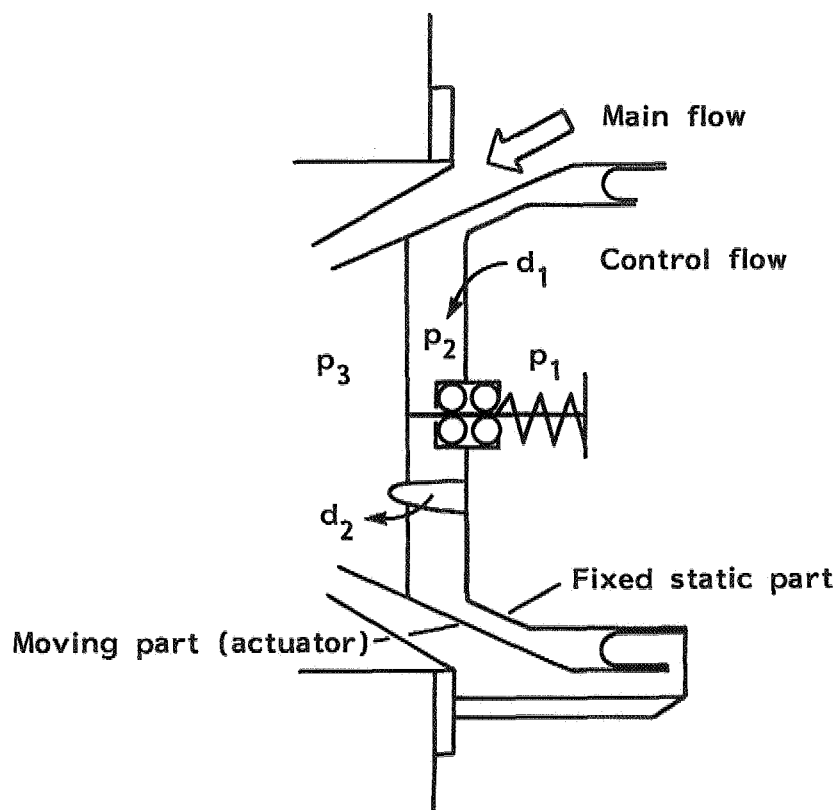

Figure 11: Example of a constant flow-rate valve

2.2 Automatic Setpoint Adjustment Systems

2.2.1 Presence Dependent Mechanical Ventilation

Objective:

Operate the ventilation system only at occupancy.

Description:

Intermittently used rooms, like toilets and bathrooms have polluted sources that are strongly related to the presence of persons. If these rooms are windowless, the fan of the ventilation system may be operated by the light switch, thus relating ventilation and occupancy. Toilet ventilation may also be controlled by the seat operation. For the replacement of the polluted air remaining after occupancy, often a delayed switch-off is applied. Another appearance of a presence dependent ventilation system is a school ventilation system operated on the main doorlock. This system may be provided with a secondary manually operated control to correct for underoccupancy during staff meetings, cleaning activities etc. In situations such as a school where a more or less fixed relation between time and occupancy occurs, the system also may be operated by a timer. A control system may be applied to not only a fan, but also to valves on supply or exhaust terminals, thus allowing a more decentral control to compensate for local variations in occupancy. An example of this is the local ventilation in a fixed seat auditorium via supply-slots in the seat-backs controlled by the seat operation. In all these different cases the control type is on/off.

Applications:

Intermittently used seats, rooms or buildings.

Properties:

- * The control systems are often based on fixed relations between ventilation (time) occupancy with ignorance of the number of occupants, the variation of the emission per occupant and the absorption and delayed desorption of pollutants.
- * The control system is often applied to the total ventilation system which may cause unnecessary ventilation of system connected rooms.
- * Most control systems have limited applications, e.g. the light switch control is not applicable to day-lighted rooms.

Benefits:

- * The operation of the ventilation system is restricted to expected polluting periods thus allowing energy conservation and an extended life-cycle of the system.

Reference:

AIRBASE Nr.2319 and 3219.

DERWENT access nr. 87-008853, 89-036671 and 89-366901.

2.2.2 Carbon Dioxide and Odour Controlled Ventilation

Objective:

Provide ventilation rates commensurating the strength of human-originating sources.

Description:

Most ventilation standards assume levels sufficient to remove those pollutants generated by man, i.e. human odours and vapour. This can be superseded by the demands for tobacco smoke, if smoking is involved. Detection of these pollutants will give a representative signal for ventilation control.

The types of sensors used for detection of human-originating pollutants are: (i) carbon dioxide sensors, (ii) mixed gas sensors.

The carbon dioxide sensors are based on the assumption that human generated carbon dioxide is representative for the human odour production.

The mixed gas sensors rely on the combustability of a number of human generated gasses such as hydrocarbons, esters and water vapour. The sensors' sensibility to non-oxidised gasses cause it also to react on tobacco smoke. The carbon dioxide sensors are based on the principle of absorption of selected infrared radiation by the gas. The absorbed energy is converted into an electric signal. Accuracy of the measured carbon dioxide concentration is between 10 and 100 ppm and response times are about three minutes.

The mixed gas sensors are based on two principles: - the semi-conductor type, where the conductivity changes due to the reaction of gases with the oxygen on a metal oxide surface; and - the catalytic type, where the heat emission of a heated wire is affected by the exothermic reaction of the gas with a catalytic acting metal surface around the wire.

Most properties of these still developing mixed gas sensor types are yet unknown, or unsatisfactory for their use in the long term.

The sensor signals can be used to control different types of ventilation systems. Because of the present costs of sensor control systems, they are only applied on

whole building or dwelling ventilation systems rather than controlling the ventilation per room. This means the sensor will be located in the central exhaust duct of each dwelling.

The controlled parts may be:

- supply and/or exhaust fans;
- valves in the main supply and/or exhaust duct;
- servo-controlled supply vents in walls or windows.

These components may be part of a mechanical exhaust or a mechanical supply and exhaust system for either each dwelling or a block of flats. The control type may vary from a stage control (low/medium/high) to a PID-control. The effectiveness of the ventilation system may be significantly improved by adding a (manual) control on local terminal devices, e.g. from a kitchen or bathroom. The aim of this is to increase the local ventilation of a room by adjusting the distribution of ventilation air between rooms rather than increasing the total ventilation of the dwelling.

Because of the variation of human pollutants-production the ventilation demands are also variable. In practice a flow rate variation in a ratio of about 1 to 4 is experienced. This variation of supply airflows may cause draughts especially when the supply air is unheated or cooled. To prevent draughts (i) preheating, (ii) slot adjustment of the supply terminals, or (iii) mixing of ventilation air with room- air to a smaller temperature difference and a more constant flow may be advisable (Fig. 12). Each solution will put extra demands on the ventilation system.

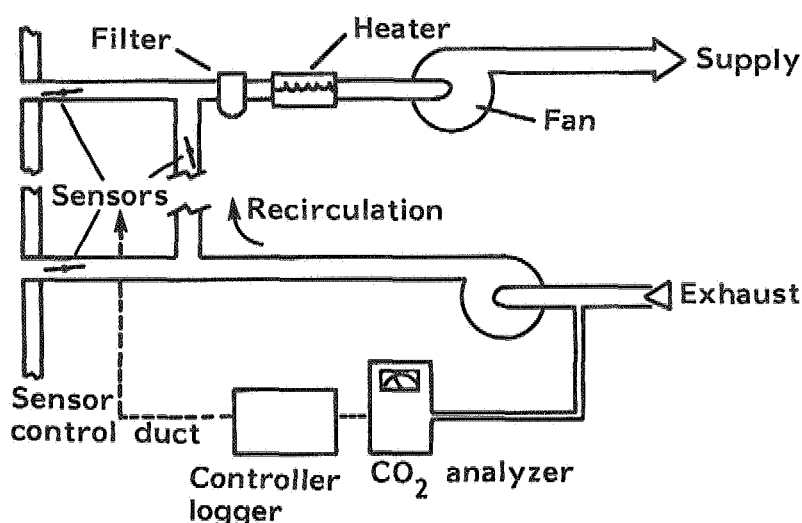

Figure 12: Schematic of ventilation control system with mixing of recirculation air to provide a constant flow.

Other demands due to the flow variation concern:

- The duct design. Each duct has to be designed for its maximum flow to prevent high pressure losses and noise-generation;

The heating system. A variable ventilation flow causes a variation of the heating demand. To prevent room temperature fluctuations an adjustment of the room heating system or the ventilation air heating system is preferable. The desired speed of adjustment may put extra demands on the dynamic properties of the heating and heating control system.

Applications:

Dwellings, functional and industrial buildings.

Properties:

- * The control, only on human-originating pollutants, is leading to ventilation flows, which are occasionally superseded by the ventilation need for vapour sources.
- * Creating a constant maximum allowable concentration of indoor air pollutants still may be questionable from a health point of view, knowing that some health effects might be unknown. This is one reason why most systems operate on setpoints well below the maximum allowable level.
- * The sensor signal does not have to be representative for human exposure, because of differences in location and sensitivity .
- * The sensor types regarded are not selective to human originating pollutants. For instance, they also react on carbon dioxide for combustion appliances as being representative of human odours.
- * The costs of the present systems do not allow individual room control though this may alter due to future developments of sensor techniques and scanner systems.
- * A combined control of both supply and exhaust provisions is recommended to prevent unfavourable (de)pressurization effects.
- * The average duct dimensions will be increased due to the design on peak loads rather than on average loads. This accounts especially for large rooms with an intermittent use.
- * The flow control of individual apartments in a central block ventilation system might influence the flows in other apartments. Reduction of these effects puts demands on the system design, e.g. a high percentage of the total

pressure loss on the terminal devices and a small effect of pressure variations on the flow rate of the fan.

Benefits:

- * Experiences with the system show a ventilation energy conservation potential of 8 to 40% compared with traditional systems.
- * The ventilation has a good agreement with the individual needs.
- * The system may automatically compensate for variable infiltration losses and system disturbances due to weather changes, air leakage of the building and other control measures, as long as they do not exceed the incidental ventilation need.
- * The control system may also be applied for safety, maintenance or automation purposes.

References:

AIRBASE Nrs.961,1022,1051,1132,1133,
1181,1218,1370,1410,1590,1827,2021,2108,
2153,2156,2275,2298,2320,2333,2480,2590,
2599,2693,2805,2912,3114,3148,3219,3251 and 3548.

DERWENT access nr.08-082328.

Paper to the 11th AIVC Conference by M. Luoma, Technical Research Centre, Espoo, Finland.

Commercial documentation of TKE-Vento, Holland.

2.2.3 Humidity Controlled Ventilation

Objective:

Provide ventilation rates commensurating the indoor vapour loads.

Description:

In contrast to the carbon dioxide or odour controlled ventilation systems (see Category 2.2.2), the humidity controlled ventilation systems are based on vapour loads, being the other main component for basic ventilation. The control system always assumes a lower absolute humidity outdoors than indoors. By controlling the ventilation, dependent on the indoor relative humidity, building damage due to condensation as well as mould growth are to be prevented.

The types of sensors used for detection are:

- (i) Hygroscopic materials like hair or polyethylene, changing their length with variation of the relative humidity.
- (ii) Capacitive materials changing their electrical capacity with relative humidity.
- (iii) Conductive hygroscopic materials changing their conductivity with relative humidity.
- (iv) Lithium Chloride sensors in which the saturation temperature is determined by heating the lithium chloride solution until water absorption stops.

The length changing materials do not have a long-term reliability due to permanent length changes by strain and changing elasticity.

Capacitive sensors are sensitive to contaminations of the air.

The lithium chloride sensors have a long response-time and are unsuitable for highly dynamic conditions.

The conductive sensors appear to be the most suitable ones with a high accuracy, short response times and no need for recalibration.

The sensor signals may be used to control different types of ventilation systems, generally after conversion of the sensor signal into an electric control signal. The control system may be applied to the same types of ventilation system or ventilation parts as mentioned for carbon dioxide or odour control (see Category 2.2.2). These systems may be completed with a passive humidity controlled wall-vent using the changing length of a plastic hygroscopic strip to directly adjust the ventilation opening area (see Fig. 13). This low-cost device is applicable to both natural and mechanical exhaust only ventilation systems.

The long term reliability of the sensors is as of yet unknown as data regarding this is not available. A remark is to be made on the long-term reliability because of the sensor principle applied. Data on this aspect is not available.

Also noticeable is the availability of integrated parts, such as local ventilation-units consisting of an exhaust fan with humidity sensor and control system, sometimes extended with a manual or light switch control and delayed switch off.

The control type may vary from an on/off to a PID-control. Several suppliers consider a differential control type favourable because of its ability to react quickly to sudden changes. Most systems do have a wide control range which often is adjustable by the occupants.

The occurring flow variation, due to changes in vapour production, is in the same ratio as for the carbon dioxide or odour controlled systems. This means the same

remarks concerning flow variation are valid (see Category 2.2.2).

Applications:

Dwellings and industrial processes.

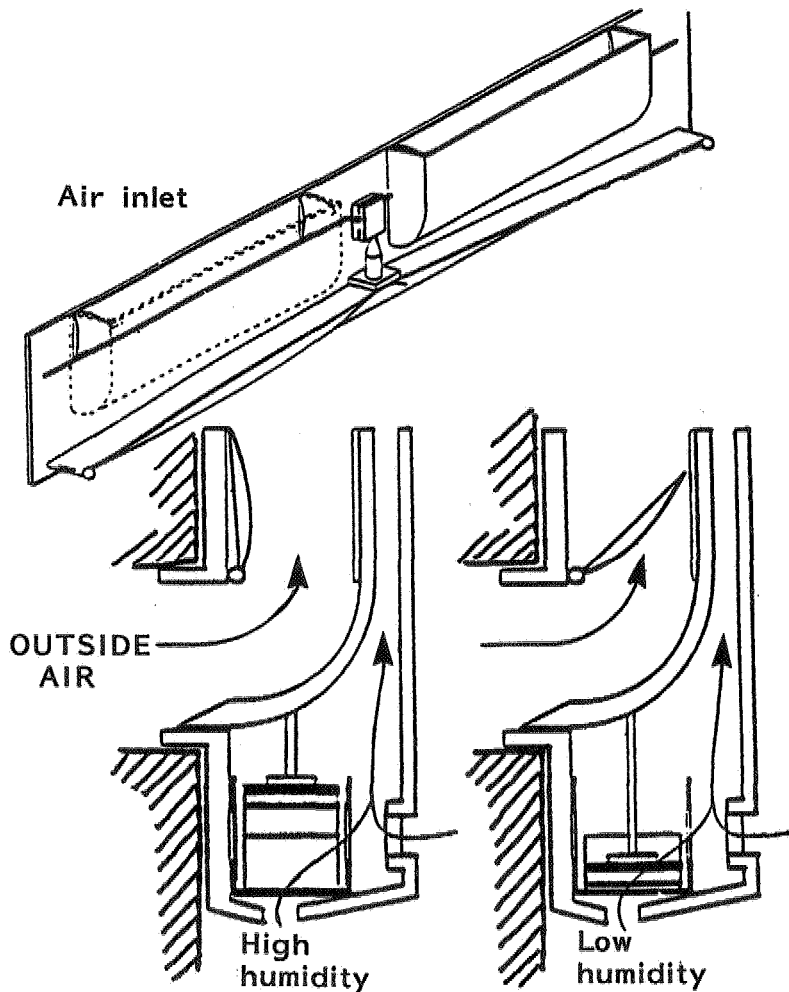

Figure 13: A passive humidity-controlled air inlet

Properties:

- * The relative humidity in dwellings is very much dependent on outside conditions. While ventilation in autumn may be maximum, it may get minimal in winter, though household vapour production and occupancy are unchanged. This means that indoor humidity sensors are unsuitable to control ventilation when occupancy related pollution sources are dominating.

- * Effective humidity control needs immediate local exhaust near the vapour sources with sufficiently high flow rates to strongly prevent dispersion to the dwelling. In general, commonly used ventilation systems barely meet this requirement, thus limiting the potential of the humidity control system. Except for higher flow rates, improvement would need local detection to establish not only the source-strength but also the source-location. This would allow control of local exhaust terminals to apply the main flow to the source location. These system adjustments will increase the installation costs, while the total operation time will be decreased.
- * Humidity controlled ventilation systems do not compensate for higher outside humidity levels.
- * Just like the carbon dioxide controlled ventilation systems, humidity control has system-implications on:
 - combined control of supply and exhaust provisions,
 - increase of duct dimensions, and
 - pressure losses on terminal devices and fan properties (see Category 2.2.2).

Benefits:

- * The system has a ventilation energy conservation potential of 8 to 40%, compared with traditional systems. The potential is even expected to rise with improved local source control, which is possible with the system.
- * The ventilation has a good agreement with the vapour loads. This automatically corrects for reduced ventilation needs in winter, thus reducing both energy demands and possible discomfort due to incoming air.
- * The system may automatically compensate for variable infiltration losses and system disturbances.

References:

AIRBASE Nrs.80,223,369,591,680,1213,1293,
 1318,1611,1651,1675,1790,1829,1935,2111,
 2132,2314,2382,2441,2497,2556,2595,2694,
 2709,2999,3003,3008,3009,3013,3021,3027,
 3028,3030,3140,3161,3176,3233,3243,3328, 3548,3622 and 3741.
 IBSEDEX Nr.8700102
 DERWENT Nr.88-222092. Papers to the 11th AIVC Conference from: H.Hens,
 Dept of Building Physics, Leuven, Belgium, (final reports Annex 14,
 "Condensation and Energy");
 M. Szerman et al, Fraunhofer Inst. of Building Physics, Stuttgart, Germany;
 Commercial documentation of INTERVENT , Holland;
 TKE, Holland and XPELAIR, Holland.

2.2.4 Temperature Controlled Ventilation

Objective:

Provide ventilation rates commensurate with indoor heat loads.

Description:

In certain cases with cool outdoor conditions, the heat load may be the dominating ventilation need. Some examples are:

- cowsheds,
- electrical power stations,
- industrial processes.

Different types of common temperature sensors may be used for ventilation control. The control may be either active, using an electrical output signal of the temperature sensor to activate fans or control valves, or passive, using, for instance, a bimetallic spring to adjust a vent. An advanced application concerns a naturally ventilated dairy barn. In this particular case the temperature sensors are not only used to calculate the required ventilation rate. The computer also calculates the optimal adjustment of the different vents to reach and distribute the required flow. It uses not only the temperature-signal, but also additional wind information and takes into account restrictions concerning possible draughts of supplied air.

Applications:

Agricultural and industrial buildings with high heatloads. Properties:

- * Not applicable to heated rooms because the system interacts with the heating system.
- * Only applicable if the ventilation need for heat removal exceeds other basic ventilation needs.

Benefits:

- * Automatic correction of variable indoor heat-loads, variable outside conditions and heat accumulation by the building.
- * Allows optimum indoor climate.

References:

AIRBASE Nr.1823.
DERWENT Nr.89-121897.

Category 3: Ventilation Heat Recovery Systems

3.1 Air-to-air Heat Recovery

Objective:

Recovery of heat losses from exhausted air, to preheat supply air.

Description:

When ventilation heat-losses become high, recovery of heat from exhausted ventilation or combustion air to preheat supply air may become favourable. There are different types of air-to-air heat recovery systems (Figure 14). Their basic principle is to exhaust air through a heat exchanger, from which the recovered heat is transported to the supply air in a reverse way. In this process exhaust air decreases in temperature, thus releasing heat. If this cooling-down is continued the air may reach its saturation point.

This means it is not capable any more of containing its vapour load, so condensation occurs. At this stage extra heat is released which is necessary to keep the water evaporated. A drain is needed to remove the condensation. There is a risk at this stage of the condensation freezing against a cold heat-exchanger surface, thus restricting or closing down the airpath.

A way to increase the total heat recovered, is by not only decreasing the temperature (sensible heat) of the exhaust air, but also decreasing the heat load for moisture-containment (latent heat), even before condensation occurs. The exhaust air is in contact with a hygroscopic material or a salt solution, which absorbs water vapour and releases it again when in contact with the supply air.

Apart from heat recovery in different varieties the heat exchangers may also be able to recover moisture, or the cooling load of the air.

The different types of heat exchangers for heat recovery are mentioned with their main features in Figure 14. The most common one for dwellings is the Plate type. It uses the cross or counterflow of exhaust and supply air through fixed surfaces of materials like metal, plastic, fibre or paper to exchange the heat. Frost control occurs by changing or bypassing the airstreams.

SCHEMATICS	FEATURES
	<p>ROTARY</p> <ul style="list-style-type: none"> Sensible and latent heat recovery Minimal cross contamination Purge section required Mechanical driver required Frost control available Close proximity of supply and exhaust
	<p>COIL LOOP RUNAROUND</p> <ul style="list-style-type: none"> Sensible heat recovery No cross contamination Pump required Frost control available Flexibility of exhaust and supply
	<p>OPEN RUNAROUND</p> <ul style="list-style-type: none"> Sensible and latent recovery No cross contamination Pump required Make-up water required Flexibility of Exhaust and supply
	<p>HEAT PIPE</p> <ul style="list-style-type: none"> Sensible heat recovery No cross contamination No pumps or drives required Frost control available
	<p>PLATE</p> <ul style="list-style-type: none"> Sensible heat recovery No cross contamination No pumps or drives required Frost control available Close proximity of supply and exhaust

Figure 14: Types of Energy Recovery Devices

The Rotary type is also commonly used. It consists of a mechanical revolving cylinder, composed of air-permeable and often also hygroscopic material. The sections of the wheel are alternately heated by exhaust air and cooled by supply air, due to its rotation. Exhaust air remaining in the wheel may cause some cross-contamination of supply air. Frosting is controlled by the speed of the wheel.

The Coil loop run around type consists of two finned-tube watercoils in the airstreams between which heat is exchanged by circulating a fluid from one coil to the other. Frosting is prevented by bypassing the fluid over a three-way control valve.

The open run around type alternately contacts the airstreams with a hygroscopic liquid (salt solution), to transport both heat and moisture. It has no frosting problems.

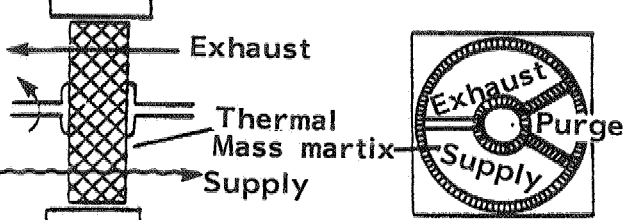
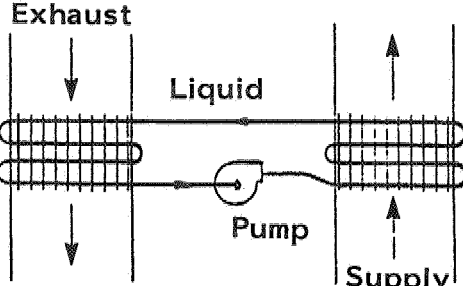
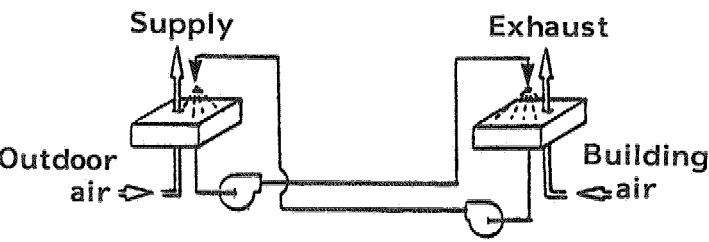
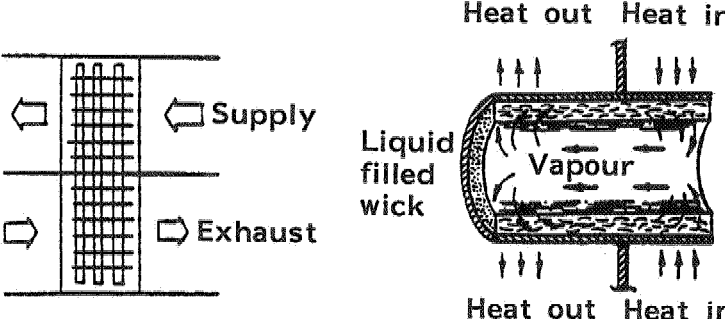
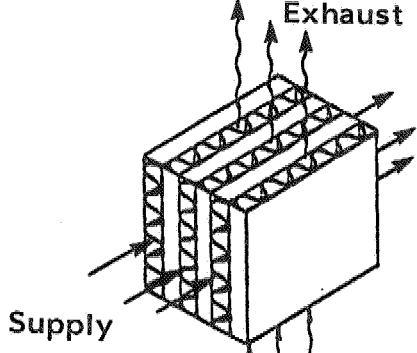
The heat pipe contains a fluid which evaporates at the exhaust air side, thus gaining heat which condenses at the supply side, thus delivering heat. The condensed fluid is transported through the heat pipe section by capillary action. Frost control may be accomplished by tilting the pipe or bypassing the air.

A variety of the heat pipe is the thermosiphon. It operates in the same way as the heat pipe but the fluid returns by gravity.

Applications:

Dwellings, functional and industrial buildings.

Properties:

- * Air-to-air heat recovery is only applicable to mechanical supply and exhaust systems. It needs nearly balanced flows to get the highest efficiency. In practice, however, some overdimensioning of the exhaust flow may be favourable to avoid moisture damage to the building envelope, to provide the warmest supply air and to reduce non-recoverable infiltration heat losses.
- * Frosting up problems in air-to-air heat recovery units need defrost mechanisms which reduce efficiency and increase the costs. From this point of view, the rotary and the open run around type of heat recovery may be advantageous because of their vapour absorption and recovery properties. What's more their increased moisture recovery during cold climatic periods may be favourable for the indoor climate, without creating vapour risks. However, moisture transfer may affect the indoor air quality.
- * Air-to-air heat recovery systems proved to be hardly cost effective in moderate climates. A minimum of 3500 annual heating degree days is

indicated as a limit for economic use. Incorporation of heat recovery from combustion products may positively alter this limit.

- * Most air-to-air heat exchangers need the close proximity of supply and exhaust. Air intake nearby the exhaust opening may increase the risk of short circuiting the exhaust air.

Benefits:

- * Air-to-air heat exchangers are capable of recovering 50 to 80% of the heat loss of the passing air which in practice will be 30 to 60% of the total ventilation heat loss.
- * Air-to-air heat recovery has proven to be cost effective in cold climates.
- * Heat recovery systems with moisture-exchange may improve the indoor climate concerning the relative humidity in cold period, thus avoiding the use of energy consuming humidifiers. At the same time they do not affect the desired moisture removal characteristics of the ventilation system in mild weather conditions.
- * High efficiency heat recovery in moderate climates is capable of preventing draughts from incoming air without auxiliary heating.
- * Heat recovery reduces the size of the heating equipment.

References:

AIRBASE Nrs.691,799,892,941,972,1033,
1181,1190,1208,1231,1682,1703,1790,1865, 2625,2914,3027 and 3593.
IBSEDEX Nrs.76005128,79002692,29008268,
79006136,84001236,87006964,88009412 and 89008320.

DERWENT Nbr.86-205331.

Paper to the 11th AIVC Conference of J.Lilly, British Gas, London, UK.
Publication of J.Cauberg in "Bouwwereld'85", Holland. Commercial
documentation of AIR CHANGER, Mississauga, Ontario, Canada.

3.2 Air To Heat Pump Systems

Objective:

Recover heat from exhaust air.

Description:

The heat pump has a closed circuit containing a fluid. The fluid is allowed to evaporate freely, while expanding in the low pressure section of the circuit,

Figure 15: Heat Pump Heat Recovery

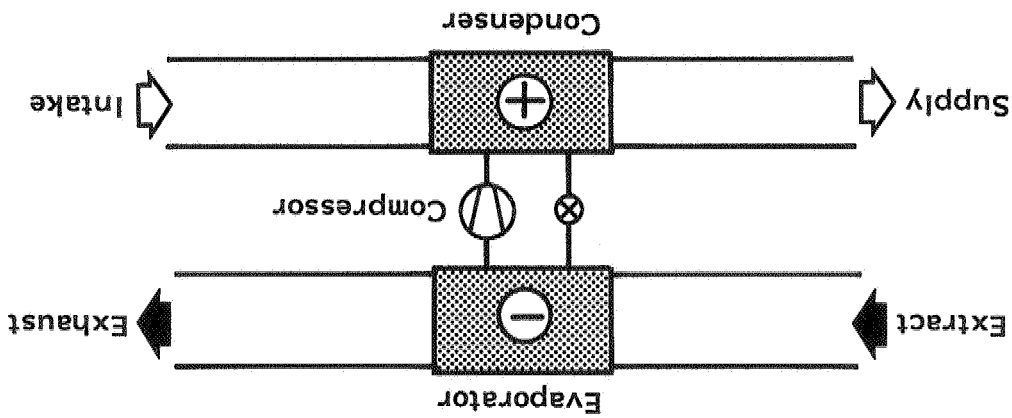

An often used application is heat pump recovery on mechanical exhaust only systems to heat domestic hot water. In general, the efficiency of the heat pump is the best when the temperature differences over both heat exchanging sections are high. This means that the supply of heat to a low temperature medium is favourable.

- fresh incoming ventilation air,
- recirculation air of an air-heating or an air-conditioning system,
- a domestic hot water system,
- a floor heating system.

The following are some examples of where the recovered heat can be supplied to:

The evaporator-section is mounted on the exhaust duct to recover heat from the exhaust air. The recovered heat may be used as an energy source for different purposes by adjusting the condenser's location. The condenser section are heat-exchangers. Both the evaporation section and the condensation section are heat-exchangers. This heat is given off in the condensation section after which the cooled fluid is flowing to the evaporation section, starting the cycle again. The evaporator section and the condenser section are heat-exchangers.

The increasing pressure, due to the compression, causes the vapour to condense to a fluid again, thereby raising its temperature due to the release of

thereby gaining its evaporation heat from its surroundings (Figure 15). In the next stage the vapour is transported by a compressor, powered by an electric or gas fired motor.

Applications:

Dwellings, functional and industrial buildings.

Properties:

- * The usability of heat pump systems is restricted by the availability of a more or less constant heat source with a limited minimum temperature to extract heat. It also needs a medium, with a limited maximum temperature, to supply its heat to. This restricts the possible applications.
- * Often, the use of an additional heating system is still necessary due to occurring temperature variations of the heat collection and the heat receiving medium and due to the restricted output temperature of the heat pump. Though the heat pump might generate a significant part of the total heat demand, often the maximum power demand of the additional heating system is just slightly reduced. This means the total costs of both systems are relatively high compared to a conventional system.
- * Most heat pumps operate on electrical energy. Since this is the most expensive energy type in a lot of countries, the economy of the system is impaired by this.

Benefits:

- * Heat pumps have the ability to recover heat from a low temperature source, for use in a higher temperature medium. This allows the application of heat recovery on exhaust only systems.
- * Heat pumps are able to recover 20 to 40% of the ventilation energy of exhaust only systems, in combination with heating of domestic hot water. Up to 95% of the heating demand for hot water may be covered while back-up may be economically provided by an electric resistance heater.
- * The heat pump system may be applied on different energy sources, including its own electric power losses.
- * The heat pump is also applicable for cooling purposes, such as food refrigeration and space cooling. A combined purpose system may improve the economy of the system.
- * The heat pump can be used for dehumidification of indoor air, thus reducing the ventilation need.

References:

- * AIRBASE Nrs.80,591,599,665,705,847,930,
1926,2118,2282,2361,2972,3029,3325,3465, 3515 and 3696.
IBSEDEX Nrs.82005820,84001236,87007120 and 88009412.

3.3 Heat Recovery Air Supply Windows

Objective:

Preheating supply air by recovered, conductive heat losses of a window.

Description:

The conductive heat losses of windows are a relatively large part of the total conductive losses of a dwelling, especially in well-insulated buildings. While windows are often used to supply ventilation air, heat exchange from the conductive outflow, possibly enlarged by solar gain, to the crossing cold air may be obvious. The inner surfaces of the window pane are used to exchange both heat fluxes (Figure 16). The fresh air inlet is situated down the outer pane and the outlet up the inner pane, to allow the generation of a low-velocity stack flow, enforced by the natural or mechanical exhaust system. The stack effect also reduces backdraughting.

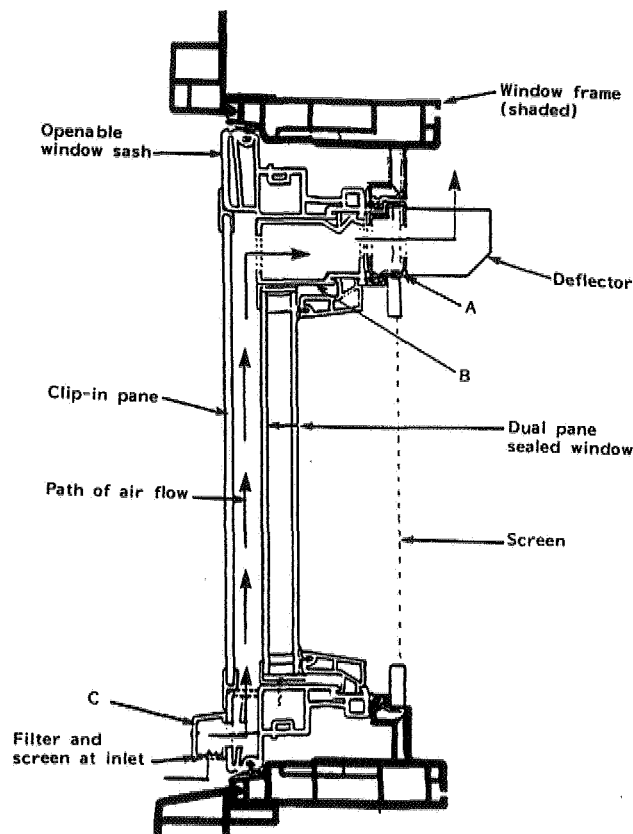

Figure 16: Preheating of supply air by conductive heat losses of the window.

An alternative to this system is to draw the supply air through the parapet behind the radiator to recover the enlarged local conductive heat losses due to the hot radiator, as well as to reduce draughts of incoming cold air.

Applications:

Dwellings and functional buildings.

Properties:

The flow velocity between the window panes must be kept low to prevent a significant increase of the window conductive heat loss as well as an increased condensation risk on the inside pane, increased cold radiation and indoor air downdraughts. This means large window areas are needed to preheat all ventilation air . This leads to high investments.

- * Not fulfilling the condition of a low flow velocity may look favourable, leading to a significant temperature rise of incoming air, but the increase of conductive heat loss reduces the overall energetic benefit.
- * The total energetic benefit is still questionable compared to the effect of a closed extra insulating layer on the conductive heat loss.

Benefits:

- * The system, when properly constructed, leads to both an energetic benefit and higher supply air temperatures, the latter improving thermal comfort compared to a non-heated air supply.

References:

AIRBASE Nrs.2147,3579,3674 and 3741.

3.4 Dynamic Wall Heat Recovery

Objective:

Recovery of conductive heat losses of the walls, using it to preheat ventilation supply air.

Description:

Just like the heat recovery window (Category 3.3), the dynamic wall principle is based on exchanging outflowing conductive heat with incoming cold ventilation air. Only this case concerns conductive heat recovery from the walls. Since it is well known that the properties of insulation depend on the enclosure of still air or some other gas, the flow of supply air through it may look contradictory . However, there appears to be a critical velocity, beyond which the internal molecular motions become dominant for the heat transport. This critical velocity is about 0.2 mm/s. this means that each 100m² of wall surface is capable of

drawing in $20 \text{ dm}^3/\text{s}$, without affecting the insulation properties. These rates meet both the dimensions of most one-family houses as well as a significant part of their basic ventilation needs, especially if one accounts for a certain complimentary infiltration. A critical part in the dynamic wall construction is the airflow control membrane that has to take care of a proper distribution of the airflow through the insulation layer. In a testhouse a spunbonded polyolefin, air and vapour permeable membrane, fixed on fibreglass board was used for this purpose (Figure 17). Joints around door and window frames, the floor and ceiling were sealed with a specially selected tape. The air was drawn in due to depressurization of the house by the mechanical exhaust system and distributed via special collector/supply provisions to the rooms.

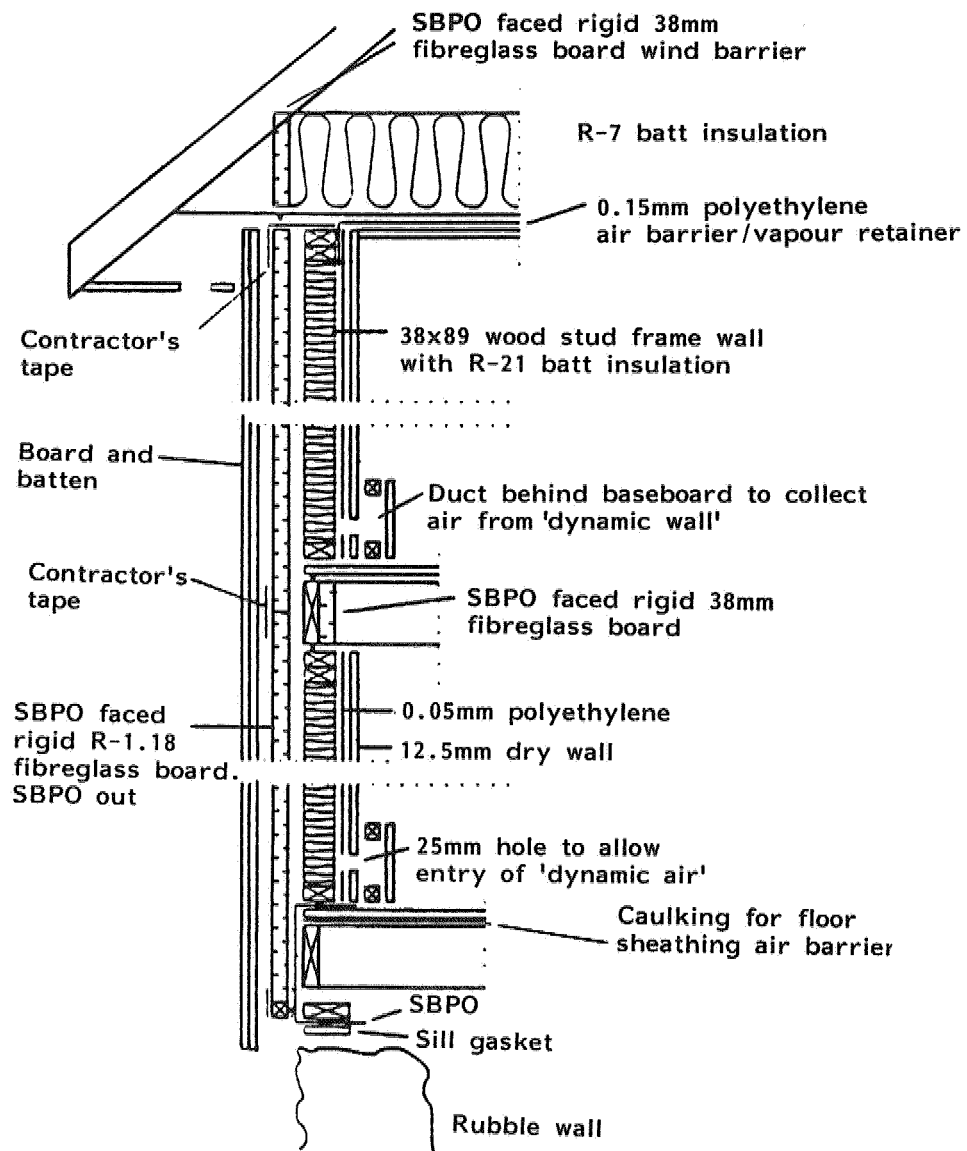

Figure 17: Cross-section of a dynamic wall

A variety of this direct-flow dynamic wall system is an indirect-flow system. This system recirculates air over the wall-in insulation, recovering conductive heat-losses with the recirculation air to a heat-pump. The heat-pump supplies the heat to the fresh incoming air.

Applications:

Experimental houses and functional buildings.

Properties:

- * A proper airflow control membrane is needed to avoid reduced insulation properties and wind cooling by air entering the cavity but not penetrating it.
- * Though some additional ventilation by infiltration is allowed, the system requires the building to have a minimum airtightness in order that a significant part of the ventilation air can recover heat through the dynamic wall.
- * Exfiltration through the air and vapour permeable wall has to be avoided to prevent moisture damage of the wall. This puts demands on the mechanical exhaust system and also on the airtightness of the building.
- * The ventilation needs of a room do not have to commensurate the room's outer wall surface area. Therefore, a distribution system for the supplied air is preferable.
- * Ventilation air passing through the different building layers may show increased concentrations of contaminants from the building materials. This can be avoided by using an indirect heat-pump system.

Benefits:

- * The part of the ventilation air supplied through the dynamic wall may be heated up to 80% of the temperature difference between outside and inside, without affecting the insulation properties. This amount can even be increased by solar gain.
- * Is capable of both heating supply-air in winter and cooling it in the summer.
- * The supplied air does not have to be heated by an additional system to prevent draughts of incoming air.
- * It reduces the need to apply massive thermal insulation by recovering most of the conductive heat-loss above a certain insulation level.
- * Needs no unrealistic construction facilities.
- * Is complementary to common mechanical exhaust systems.

* Is capable of drying the wall thus reducing vapour damage.

References:

AIRBASE Nrs.794,1663,2590,2695 and 3030.

Category 4: Alternative Ventilation Energy Gain Systems

4.1 Soil-heated or Cooled Ventilation Air

Objective:

Use the energy content of the soil to preheat or pre-cool ventilation supply air.

Description:

The supply air to a dwelling is taken in via a ground pipe or over the surface of the crawlspace to exchange heat either the soil. The principle is based on the fact that the annual temperature curve of the soil shows a delayed and smoothed reaction on the mean annual outside temperature curve. This effect is caused by accumulation and restricted heat diffusion of the soil. Both the delay period and the smoothing-out effect increase with the depth in the soil (Figure 18). They depend on the soil structure.

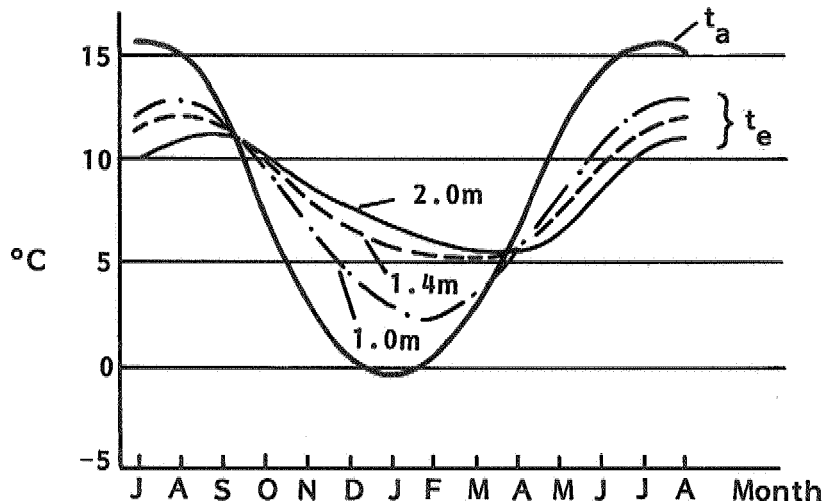

Figure 18: Example of annual temperature curves of the outside air (t_a) and the earth (t_e)

Application:
Testhouses.

Properties:

- * Both the soil temperature curves and the energy exchange with the soil are very much dependent on the type of soil and the humidity of the soil. These properties can show large local variations, which makes the system difficult to design.
- * To gain a significant energy load rather large pipelengths at a sufficient depth have to be applied. This leads to high system costs, with long pay back periods of over 9 years for individual dwellings.
- * The system supplies only preheating of supply air in the winter and precooling in summer. This means additional systems are still necessary.
- * The cheaper application of leading supply air over the ground surface of the crawlspace needs a vapour and air barrier to prevent emittance of impurities from the soil.

Benefits:

- * Possible energy savings of 10 to 23% on ventilation energy demands.
- * Smooth cooling-effect in summer.
- * One system applicable for both heating and cooling.

References:

AIRBASE Nr.3197.
IBSEDEX Nrs.86000552 and 88013160.

4.2 Solar Heated Ventilation Air

Objective:

Use the solar energy gain of building integrated components to preheat ventilation air.

Description:

Not only specially designed solar collectors have the ability to gain solar energy. In principle each exposed surface of a building material is capable of doing so. To improve the efficiency of a solar collecting surface, a combination with a glass layer is to be recommended. It allows solar radiation to pass, but once converted into heat it is captured and only allowed to escape by conduction (greenhouse-effect).

Each solar collecting surface has the highest energy gain when directed to the sun. This means that to distribute the solar heat to energy consuming places, a transporting medium has to be used. Ventilation air is a highly suitable medium for this purpose, since it is easy to transport and also needs distribution over the dwelling. Especially the use of cold supply air is recommended because of its ability to gain the highest energy loads from a collector, by maintaining a low collector temperature, thus reducing conductive energy losses.

Combined ventilation/solar gain systems may have different appearances. The use of an atrium or conservatory is a simple one. In this case preheated ventilation air may be supplied just by natural vents in both the glazing of the conservatory or atrium and the separating wall, either in combination with common natural or mechanical exhaust. The conservatory or atrium may also provide preheated air for a mechanical supply and exhaust system. Other types of ventilation/solar gain systems may use special wall or roof constructions or commercially available collectors to gain solar energy. To store solar heat the mass of the same or other building parts may be used. The advantage of heat storage is an extended use of the system during short non-sunny periods or at night. In these systems often reversible flows are used to load and unload the thermal accumulator.

The transporting airflows may be generated by thermal buoyancy (passive systems) or by fans (active systems).

Application:
Dwellings.

Properties:

- * In general solar gains are not parallel with heat demands. This means an auxiliary heating system is still necessary. A combination with solar heat storage, using the building mass, may improve the applicability of solar gain systems, but has large implications on building design and system design. The most promising system is supposed to be a hybrid system of a solar collector with direct storage and mainly natural ventilation, integrated in the building design. The cost effectiveness of such a system is yet to be proved.
- * Energy gain with atria and conservatories needs a controlled one-directional flow of supply air to the dwelling. In practice the energy gain of atria and conservatories is highly reduced or even changed into energy loss, by using them as additional rooms. This type of use leads to a highly increased air exchange with the adjacent well-insulated rooms and even to the application of additional heating in the atrium or conservatory.

- * Atria and conservatories need their own additional ventilation provisions or a bypass for the supply air to the dwelling to prevent overheating of ventilation air in the summer.
- * Atria and conservatories hardly give any reduction of the conductive heat losses of the adjacent walls, with present insulation levels.
- * Atria and conservatories prefer massive wall and floor surfaces to prevent large daily temperature fluctuations of supply air.

Benefits:

- * Calculations on advanced solar collector systems predict a potential energy conservation up to 50% of the total demand for present space heating.
- * The combination of ventilation and solar gain is advantageous, because of the ability of ventilation air to transport and distribute the solar heat. What is more, the cold supply air allows a high efficiency of the solar collector. In combination with air to air heat recovery, solar heat may be used to defrost the heat exchanger.
- * The basic concept of atrium and conservatory is capable of reducing the ventilation energy demand. It also increased the amenity of an otherwise open court.

References:

AIRBASE Nrs.147,794,1519,2419,2420 and 2587.

IBSEDEX Nrs.79005784 and 83014408. DERWENT Nrs.87-095802, 88-097412 and 89-204931.

Report Nr.R88/397 of MT-TNO, Holland.

APPENDIX C

CLASSIFICATION OF VENTILATION SYSTEMS

C 1 Introduction

The classification of ventilation systems needs a proper description of each system, followed by a validation of its main properties. The properties of the system may be established using a number of questions. By giving qualifications or ratings to the answers to these questions the main characteristics of each ventilation system may be classified qualitatively or numerically. This appendix suggests a first approach to such a system for the classification of ventilation systems. To optimize the classification system it is suggested to use a calculation model for ventilation and concentrations to generate objective ratings. These ratings may be completed with the mean subjective opinion of a team of experts.

C 2 Description of Ventilation Provisions

For representative rooms the ventilation provisions for basic ventilation needs are characterised by the following code:

Room ventilation type:

	Supply	Exhaust
Natural	[NS]	[NE]
Mechanical	[MS]	[ME]

Room ventilation provisions for supply/exhaust:

1. No special provisions/cracks and gaps
2. Trickle ventilator(s)/fixed vent(s)
3. Openable casement window(s)
4. Openable wall - or window grille(s)/small top hung window(s)
5. Local fan(s)
6. Connection(s) on central duct system
7. Overflow provision(s) in internal wall(s)

Using this code the ventilation provisions of a dwelling may be characterised for instance like:

- habitable rooms:
 - living rooms and bedrooms NS3/4, NE7
- service rooms:
 - bathrooms and WC NS4/7, ME6
 - kitchen NS3/4/7, ME5/6
- other rooms
 - hall NS7, NE7

In this example the habitable rooms are provided with openable casement windows and window grilles which are basically meant for air supply, whilst overflow by special openings under the doors to the mechanical exhaust duct in the service rooms will provide exhaust. The service rooms are also provided with window grilles for air supply. The kitchen contains an additional openable casement window for air supply and a cooker hood with exhaust fan, directly ducted to the outside.

Other appearing combinations of ventilation provisions are marked in Figure C.1.

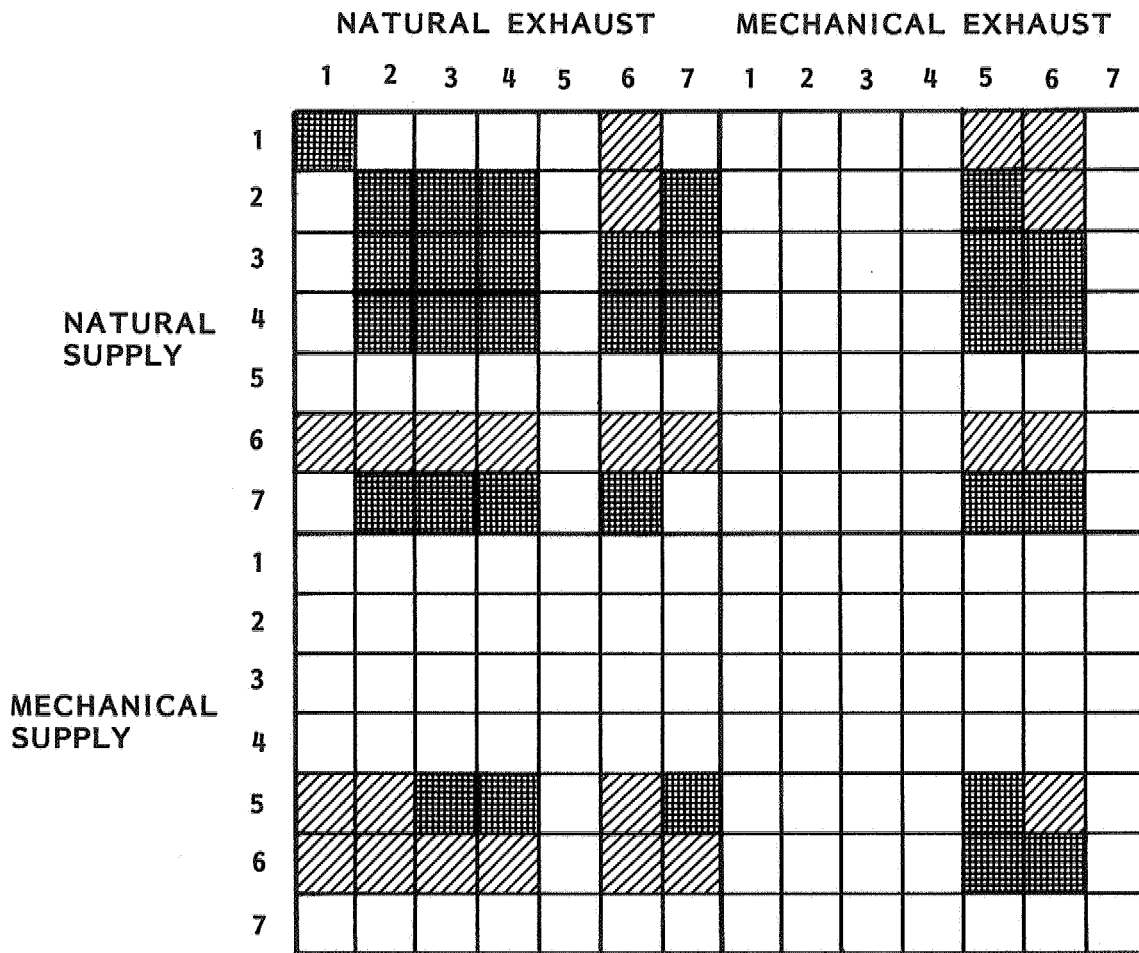

CODE:



Common system combination



Possible, but not common system

- 1 = No special provisions/cracks and gaps
- 2 = Trickle ventilator(s)/fixed vent(s)
- 3 = Openable casement window(s)
- 4 = Openable grill(s)/small top-hung window(s)
- 5 = Local fan(s)
- 6 = Connection(s) on central heating duct system
- 7 = Overflow provision(s) in internal wall(s)

Figure C1: Appearing Combinations of Provisions for the Ventilation of Rooms

C 3 Characterisation of System Properties

C 3.1 Efficient Application of Ventilation Air

C 3.1.1 Local Applicability

The ability of the ventilation system to distribute the ventilation air especially to the locations with ventilation needs may be expressed by the answers to the next questions.

	All Rooms	All Habitable & serv. Rms	Only Habitable Rooms	Only Service Rooms	One Central Location	No Location
1.0 Which locations have their own provisions for supply of fresh outside air, directly or via a duct?						
2.0 On which locations are these the dominant supply provisions?						
3.0 Which locations have their own provisions for air exhaust, directly or via a duct to the outside?						
4.0 On which locations are these the dominant exhaust provisions?						
5.0 Which locations are provided with provisions (except doors) for: 5.1 - air supply from other rooms or spaces? 5.2 - air exhaust to other rooms or spaces? 5.3 - mixing with air of other rooms or spaces?						

6.0 If there are any significant provisions that cause air exchange between rooms or spaces (see Question 5), are the main sources of pollution in these rooms/spaces comparable?

7.0 What is the chance of flow-reversion through ventilation provisions due to?:

7.1 - weather changes? (None/ Rare/ Regular/ Often)

7.2 - measures on other provisions? (None/ Rare/ Regular/ Often)

8.0 Are the main ventilation provisions for:

8.1 - fresh outside supply? (Yes/ Partly/ No)

8.2 - direct exhaust to the outside? (Yes/ Partly/ No)

8.3 - air exchange between rooms? (Yes/ Partly/ No)

to be operated separately per room?

C 3.1.2 Flowrate adjustability

The ability of the ventilation system to adjust the flowrate to the variable demands per room, may be expressed by the answers to the next questions:

9.0 Are the ventilation provisions Yes No
 designed to provide basic flowrates
 according to national standards?

Please give the specific (range of) design
 values and/or their reference(s):

	air change rate (ach)	flow rate (dm ³ /s per					opening area (cm ²)	
		room	person	floor area	window area	heat load	wall/window	duct
Habitable Rooms								
Kitchen								
Bathroom								
W. C.								
Other Rooms								
Whole Dwelling								
Combustion Apparatus								

10.0 What type(s) of control has/have been used to adjust the setpoint of ventilation provisions to changing ventilation needs?

- 1. no control (= fixed setpoint) []
- 2. manual control []
- 3. timer control []
- 4. indoor temperature control []
- 5. humidity control []
- 6. CO₂ or odours control []
- 7. others, namely.... []

11.0 Using the numbers 1 to 7 from question 10, mark which control type has been used on the following combinations of provisions and locations.

location: pro- visions for:	all rooms	all habitable and service rooms	all habitable rooms	all service rooms	one master habitable room	kitchen	bathroom	W. C.	central duct of the dwelling	central duct of building containing number of dwellings	others, namely
fresh air supply											
supply from other rooms											
mixed fresh/ recirculation supply											
direct exhaust											
exhaust to other rooms											

12.0 The flow through ventilation provisions may alter at unchanged setpoint due to weather changes or control measures on other provisions. What type of compensation has been used?

no compensation

compensation, sensing:

- outdoor temperature

- wind velocity and direction

- pressure difference

- flow rate

By giving rates to the answers of the previous questions, and by combining these rates, a total rate may be found expressing the flowrate adjustability to local variations of the source strength.

Optimum flowrate adjustability may occur when each normal variation of source strength in every room will lead immediately to a reaction of the ventilation system. In this way the indoor air quality remains at the same (set) acceptable level without affecting the ventilation flows of other rooms, and is (highly) independent of the weather changes and the use of ventilation provisions in other rooms.

C 3.1.3 Air Flow Pattern

The most efficient application of ventilation air within a room will occur when the fresh air is introduced directly into the occupied zone, and when the airflow expels all contaminants from the room with a minimum of dispersion.

This property of a ventilation system may be expressed as "ventilation-efficiency" or the "coefficient of air change performance".

Essential factors are:

- the locations and directions of air supply, compared to the occupants and sources;
- the velocity and turbulence of supplied air;
- local exhaust near sources.

The airflow pattern may be characterised in the system design.

13.0 Is the ventilation system of the next rooms designed for:

	Habitable Rooms	Kitchen	Bathroom	WC	Others Namely
Prevention of contaminant dispersion by local exhaust					
Unidirectional Plugflow					
Displacement Ventilation					
Low Velocity Supply					
Mixing Ventilation					

14.0 In the case of two or more flowtypes within one room, can any interference of a superior flowtype by an inferior one be expected?

- yes
- substantially
- slightly
- no

C 3.2 Efficient Energy Use

C 3.2.1 Auxiliary Energy Need

15.0 What is the total installed (electric) power demand for transporting (fans) and controlling (valves, servomotors, etc.,) the ventilation air?

.....kW

16.0 On which flowrate is this power demand applied ? (see also question 9)

.....m³/s

By dividing the power demand to the flowrate an expression will be found for the auxiliary energy need.

Some correction per climatic zone may be useful to compensate for the different acquired minimum pressured differences to prevent disturbance by the weather.

C 3.2.2 Ventilation Heat Demand

The ventilation heating (or cooling demand) may be generated with different types of heaters (coolers). Though the total ventilation heat demand depends on the climate (i.e. the number of degree-days) the essential factor is considered to be the efficiency of the heating and transporting system, related to primary energy-need. It is considered to be out of the scope of this report to give a classification of the heating system. Nevertheless the possibilities of gaining heat from alternative sources, or by ventilation heat recovery devices may be directly related to the ventilation system applied.

The next questions deal with these possibilities.

17.0 Is the type of ventilation heat exchanger capable of gaining its heat from (alternative) low-temperature sources?

yes []
no []

18.0 If yes, which part of the total yearly ventilation heat demand is gained from free alternative sources?

Estimate:

0% 50% 100%

19.0 Which part of the ventilation heat losses is recovered from the exhausted air?

Estimate:

0% 50% 100%

C 3.3 Costs

20.0 What are the estimated costs of the ventilation system components and their installation?

- distribution and transportation of air
- extra means for preheating the air
- control devices
- alternative energy gain devices
- heat recovery devices

[Note: In case of a (building) integrated design (e.g. a dynamic wall heat recovery) only the estimated extra costs, compared to a standard design, have to be considered].

21.0 What are the estimated yearly costs for operating the ventilation system?

- maintenance
- servicing
- auxiliary energy
- (total installed power (question 14)
X operation time X specific energy costs)
- primary ventilation heat demand
- (mean flowrate (question 9) X operation
time X mean temperature difference during
heating season X specific heat coefficient
of air X specific energy costs)
- percentage of alternative energy gain and
heat recovery (questions 18 & 19).

22.0 What are the estimated life-cycles of the ventilation system's main components?

To produce a representative expression for the total costs of the ventilation system it is suggested that the following be standardised:

- ventilation heating costs to climatic classes (i.e. the number of degree-days);
- the installation costs to a standard life-cycle;
- the resulting total costs to the flowrate.

C 3.4 Reliability

To classify ventilation systems as to their reliability will be very difficult. Each rate or qualification to be generated has to be based on experience and will be very predictive.

Some possible questions are:

23.0 What is the number of system components (system complexity)?

24.0 What types of components or combinations of components have been used (detection of critical mechanical, electrical or other components or critical combinations)?

25.0 Does the system need any commissioning, regular verification or servicing?
If so, on what specific parts of the system?

26.0 Are the operating instructions simple?

27.0 What are the chances of malfunctioning due to:

- wrong operation (wrong system settings, mechanical force),
- electromagnetic fields,
- temperature variations,
- pressure fluctuations.

Will it cause temporary or permanent disorder, partly or completely?

C 3.5 Comfort

The comfort of a ventilation system depends on the condition of the supplied air, the control of the air quality and the possibilities of interaction with the inhabitants.

28.0 Is the air quality controlled?

29.0 Is there any conditioning of the supply air?

- (de) humidification,
- pre heating/cooling,
- restriction of supply velocity fluctuations.

30.0 Is the supply air well distributed over the room? Is the ventilation air supplied directly to the occupied zone(s)?

31.0 Is the control system user-friendly?

- understandable,
- easy to manipulate,
- setpoint adjustable to individual needs,
- setpoint reproducible.

C 4 Classification

Using the questionnaire of Appendix C, a rough, rather subjective classification has been carried out for a number of common and advanced ventilation systems.

The results are shown in the following table.

The table is divided into four categories:

- (i) natural ventilation systems,
- (ii) natural supply, mechanical exhaust systems,
- (iii) mechanical supply, natural exhaust,
- (iv) mechanical supply and exhaust.

The last category is divided into mechanical ventilation for the whole dwelling, per separate room or per room zone.

The ventilation devices of the system are mentioned in the next columns, followed by the control type. The control system is applied to the ventilation devices marked "C".

Ventilation System		Efficient Application of Ventilation Air			Efficient Energy Use		Specific Costs		Reliability		Comfort	
Type	Devices (c = controlled)	Control Type	Local Applicability	Flowrate Adjustability	Airflow Pattern	Auxiliary Energy Need	Ventilation Heat Demand	Installation	Operation	Reliability	User Friendliness	Supply Conditions
Mechanical/ zone	Supply	Exhaust	+	+	+	+	.. + +	-	0	-
	local room fan (c)	local source extract (c)	+	+	-	+	.. + +	-	0	-
Mechanical/ room	local room fans (c)	local room fans (c)	+	-	-	+	[possibility of applying alternative energy gain and heat recovery]	-	0	-
	displacement grills + ducting + fan (c) + openable windows	odour or CO ₂ odour or CO ₂ humidity indoor temperature time manual	-	0	+	+		0	+	.. +
Mechanical	ducting + fan (c) + openable windows	ducting + fan (c) + openable windows	-	0	-	+		0	+	.. + +
	ducting + fan (c)	ducting + fan (c)	-	0	-	+		0	+	.. + +
Mech. supply/ Nat. exhaust	window fans (c)	grills (c)	+	+	-	+	..	-	0	+	+	-
	grills + openable windows	ducting + fan (c) + openable windows	-	0	-	+	.. + [possibility of applying heat pump heat recovery]	-	0	+	0	-
Natural supply/ Mechanical exhaust	grills (c) + openable windows	ducting + fan (c) + openable windows	-	0	-	+		0	+	.. + +
	cracks	ducting + fan (c)	-	0	-	0		0	0	+	0	0
Natural	grills (c) + openable windows	ducting + openable windows	+	+	-	+	..	0	0	-	0	-
	grills (c) + openable windows	ducting + openable windows	-	0	-	+	..	+	0	+	0	0
Natural	grills (c) openable windows	grills (c) + openable windows	-	0	-	+	..	+	0	+	0	-
	cracks	grills (c) openable windows	-	0	-	+	..	+	0	+	0	0

Table 1: Classification of Ventilation Systems

Code: + = excellent, + good, o neutral, - moderate, - - bad

THE AIR INFILTRATION AND VENTILATION CENTRE was inaugurated through the International Energy Agency and is funded by the following thirteen countries:

Belgium, Canada, Denmark, Germany, Finland, France, Italy, Netherlands, New Zealand, Norway, Sweden, Switzerland, United Kingdom and United States of America.

The Air Infiltration and Ventilation Centre provides technical support to those engaged in the study and prediction of air leakage and the consequential losses of energy in buildings. The aim is to promote the understanding of the complex air infiltration processes and to advance the effective application of energy saving measures in both the design of new buildings and the improvement of existing building stock.

Air Infiltration and Ventilation Centre

University of Warwick Science Park,
Barclays Venture Centre,
Sir William Lyons Road,
Coventry CV4 7EZ,
Great Britain.

Telephone: +44 (0) 203 692050
Fax: +44 (0) 203 416306

Operating Agent for International Energy Agency, the Oscar Faber Partnership, Upper Marlborough Road, St. Albans, UK